

Quantum QH-175

Hydronic unit

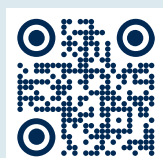

Installation and user handbook

QCH EN 2537-A
1012215

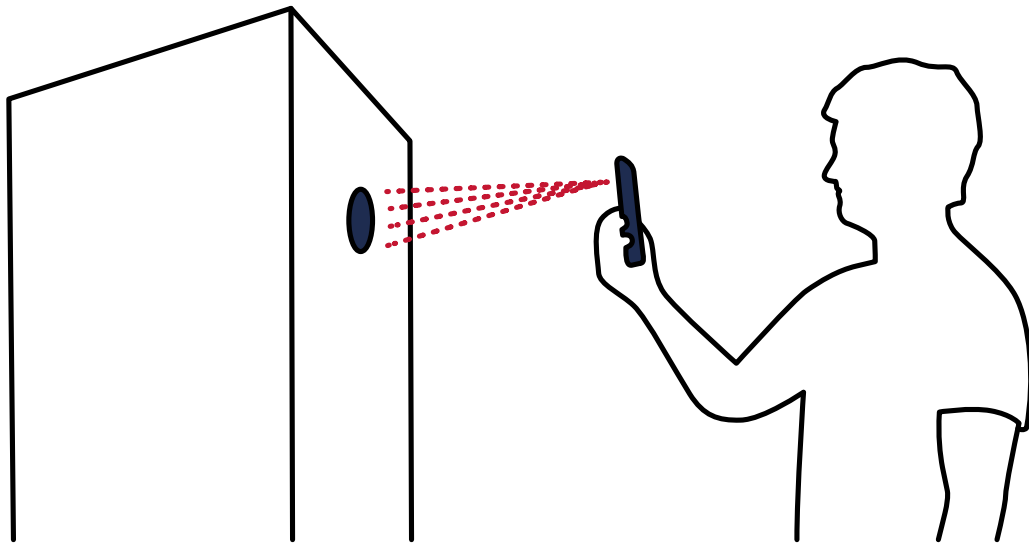

QVANTUM APP

Have all the controls for your heat pump, in the palm of your hand.

The Quantum app is a necessary companion for installing and setting up your Q unit. The app is available on both App Store and Google Play.

By scanning the QR code on your Q unit, you can connect to the unit through Wi-Fi or Bluetooth. During commissioning, you will be guided through the entire installation process.

Once the connection is established, you can use the app to access all relevant information and settings for your product.

CONTENTS

1 Important information.....	4	9 Troubleshooting.....	33
General.....	4	Before troubleshooting.....	33
Safety.....	4	Low room temperature during heating.....	33
Network interfaces and services.....	5	High room temperature during heating.....	33
Symbols.....	5	Insufficient hot water production.....	33
Product labels.....	5	Low system pressure.....	33
Serial number and QR code.....	5		
Product registration.....	5		
Environmental information.....	5	10 Technical specifications.....	34
Glossary.....	6	Dimensions.....	34
		Technical data.....	35
2 Before installing.....	7	Index.....	36
Transport.....	7		
Removal of packaging.....	7		
Front cover removal.....	7		
Removal of pallet.....	9		
Installation area.....	9		
Additional components.....	10		
3 Components.....	11		
Overview.....	11		
Plumbing connections.....	11		
Electrical box.....	11		
4 Pipe installation.....	12		
Pipe installation, general.....	12		
Pipe connections.....	13		
Installation.....	13		
5 Electrical installation.....	16		
Electrical installation, general.....	16		
Electrical connections.....	17		
Safety temperature limiter.....	21		
Settings.....	21		
6 Commissioning.....	22		
Quantum app.....	22		
Preparations.....	22		
Filling.....	23		
Venting.....	23		
First start-up.....	23		
7 User interface.....	25		
Introduction.....	25		
Using the display unit.....	25		
Indications.....	25		
Indoor climate.....	25		
Domestic hot water.....	26		
Comfort and scheduling.....	26		
Settings.....	27		
8 Service.....	29		
General.....	29		
Remote service.....	29		
Maintenance.....	29		
Service actions.....	30		

1 IMPORTANT INFORMATION

General

WARNING

Read this manual before starting the unit for the first time.

It is the owner of the product that is responsible for the system. If you suspect that the product is defective, contact your dealer.

Safety

This appliance can be used by children from 8 years and above and people with reduced physical, sensory or mental capabilities or lack of experience and knowledge if they have been given supervision or instruction concerning the use of the appliance in a safe way and understand the hazards involved. Children must not play with the appliance. Cleaning and maintenance must not be performed by children unless they are older than 8 and supervised.

The manual must be available for people who install, support or use the product.

Companies and service technicians who install or perform maintenance work on the product must be authorized and have the necessary certificates and licenses.

The work must follow applicable rules and regulations. Ensure that the work is carried out in a professional manner.

When powering up the product, there must be no frozen water in the system.

Wiring and electrical installation must be performed in compliance with national regulations.

It must be possible to safely disconnect the electrical power supply to the unit. Install the power supply with an isolator switch and size the cable area based on the fuse rating that is being used.

Operating pressures

- Distribution system
 - Min (MPa/bar): 0,05/0,5
 - Max (MPa/bar): 0,3/3

- Domestic hot water
 - Min (MPa/bar): 0,05/0,5
 - Max (MPa/bar): 0,9/9

Operating temperatures

- Distribution system
 - Min (°C): 7
 - Max (°C)¹: 80
- Domestic hot water
 - Min (°C): 1
 - Max (°C)¹: 60
- Ambient
 - Min (°C): 5
 - Max (°C): 35

Water quality

The product has a plate heat exchanger that should not be exposed to corrosive water. To avoid corrosion, the water must meet the following quality requirements.

ELEMENT/COMPOUND/PROPERTY		LIMIT
pH	-	7.5 – 9.0
Conductivity	µS/cm	< 500
Total hardness	°dH	4.5 – 8.5
Free chlorine	ppm	< 1.0
Ammonia (NH ₃)	ppm	< 0.5
Sulphate (SO ₄ ²⁻)	ppm	< 100
Hydrogen carbonate (HCO ₃)	ppm	60 – 200
(HCO ₃) / (SO ₄ ²⁻)	-	> 1.5
(Ca + Mg) / (HCO ₃)	-	> 0.5
Chloride (Cl ⁻)		See diagram.

The allowed chloride level depends on the pH of the water and the maximum temperature the plate heat exchanger is exposed to.

Do not expose the plate heat exchanger to chloride levels in the shaded area of the diagram. This can cause crevice corrosion.

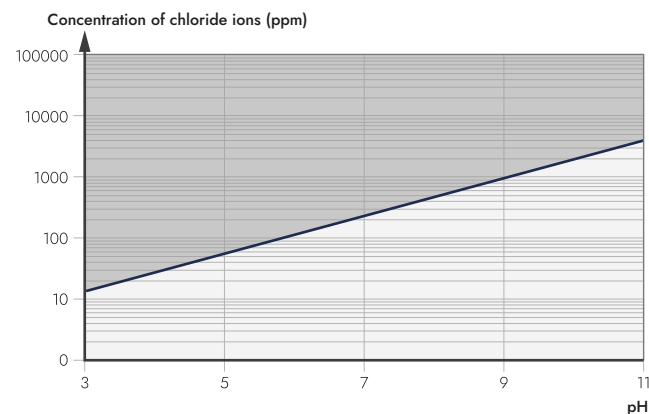

¹ With compressor and immersion heater.

Network interfaces and services

The following network interfaces and services can be exposed to the internet:

- Cloud connection (AWS IoT Hub) over Wi-Fi
- Bluetooth.

Symbols

The manual contains the following symbols

WARNING

This symbol describes information that is of great danger to people or equipment.

CAUTION

This symbol describes information that could cause danger to people or equipment.

NOTE

This symbol describes information that is crucial when installing or servicing the product.

TIP

This symbol describes information that can be helpful when installing or servicing the product.

Product labels

These labels are found on the product.

CE CE marking indicates that a product has been assessed by the manufacturer and deemed to meet EU safety, health and environmental protection requirements.

IP21 Protection classification against water and dust in the electrical enclosure.

Serial number and QR code

The serial number and QR code of the QH are visible at the following locations.

- Electrical box cover
- Packaging
- User interface.

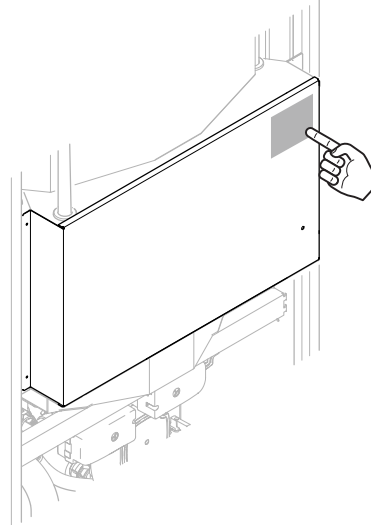

Product registration

The product must be registered for the warranty to take effect. The product can be registered no more than 12 months after the delivery date from the factory and no more than one month after the installation. If the product is registered at a later stage, the warranty period will be affected.

The product registration is done as part of the start-up guide in the Quantum app.

Environmental information

Recycling

 At the end of the electrical products useful life, it must not be disposed of with household waste.

Recycle at waste facility. Check with your local authority or retailer for local recycling regulations.

Packaging content

The product packaging contains the following materials.

MATERIAL	WEIGHT
Paper	4200 g
Plastic	230 g
Wood (pallet)	15,5 kg
Steel (reinforcement on pallet)	1 kg

Glossary

The following terms are used throughout the manual to describe various functions of the product.

Distribution system

The distribution system is the system that is used to provide the house with heating through radiators, floor heating and/or fan convectors.

Hydronic unit

The hydronic unit consists of an accumulator tank, pipe connections, electrical connections and the graphical user interface. It provides the house with domestic hot water as well as heating through the distribution system.

Heat pump unit

The Quantum QH is installed together with a heat pump unit that is placed outside of the facility. The outdoor heat pump unit draws heat from the outdoor air and transfers it to the hydronic unit .

2 BEFORE INSTALLING

Transport

Transport the product in an upright position. Ensure that the product is adequately secured so it does not fall down during transit.

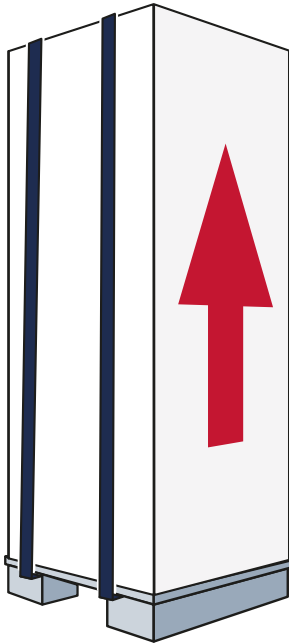

At arrival, ensure that the product was not damaged during transport.

If the product must be tilted after arrival, always tilt it backwards.

If using a trolley or hand truck when moving the product, always have the product standing on the pallet.

Removal of packaging

1. Remove the foil and paper packaging.
2. Remove the three fixing screws from the wooden plank on the front side.

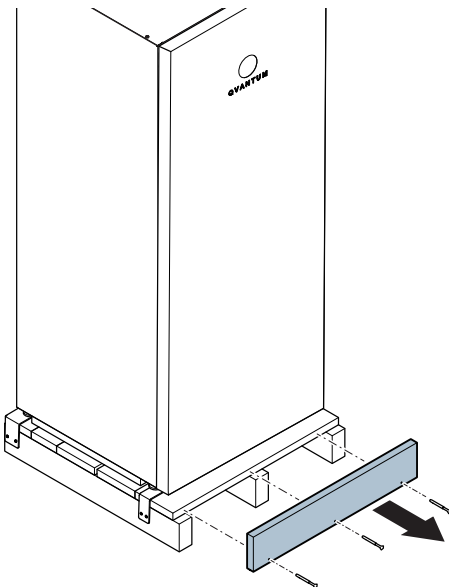

3. Remove the enclosed kits from the bottom of the product and keep them for the next steps of the installation.
4. Remove the two stiffening plates on the top of the back of the product by removing the four fixing screws.

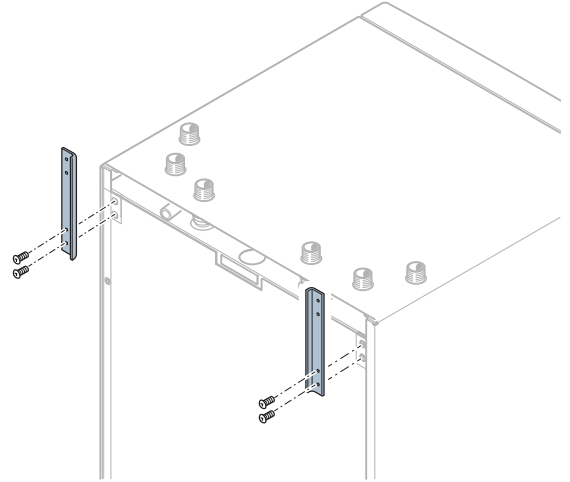

Front cover removal

The front cover of the unit is mounted with hinges placed on the bottom of the frame and on the internal sides of the front cover.



NOTE

Be careful when removing the hydronic unit cover to avoid causing damage to the ethernet cable, display unit or grounding wire.

1. Remove the blue adhesive tapes from both sides of front cover.
2. Carefully lift the front cover upwards.
3. Tilt the cover slightly from the frame.

4. Lift the cover completely and remove it from the frame.

 **NOTE**
Due to the length of the wires, place the cover to the right of the product.

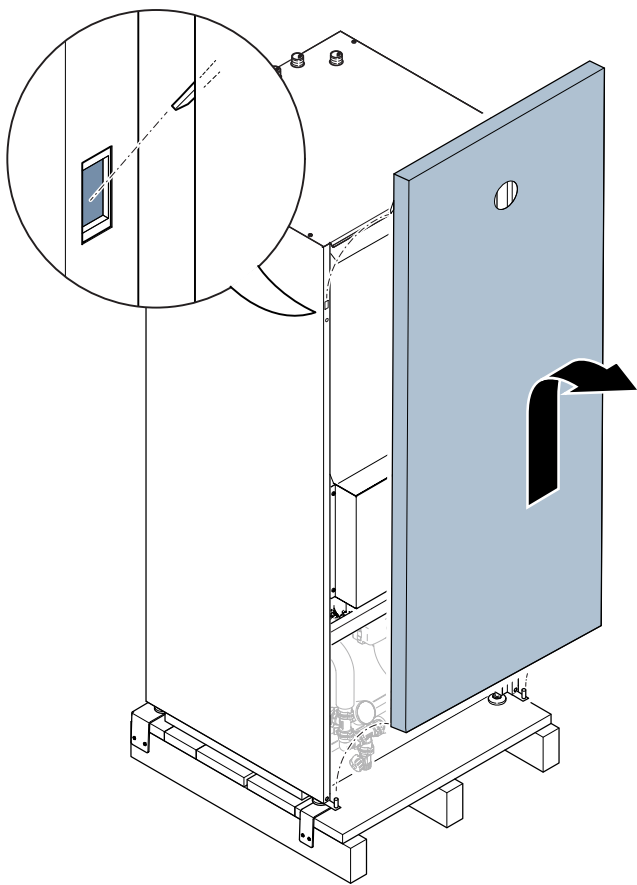

2. Disconnect or connect the ethernet plug.

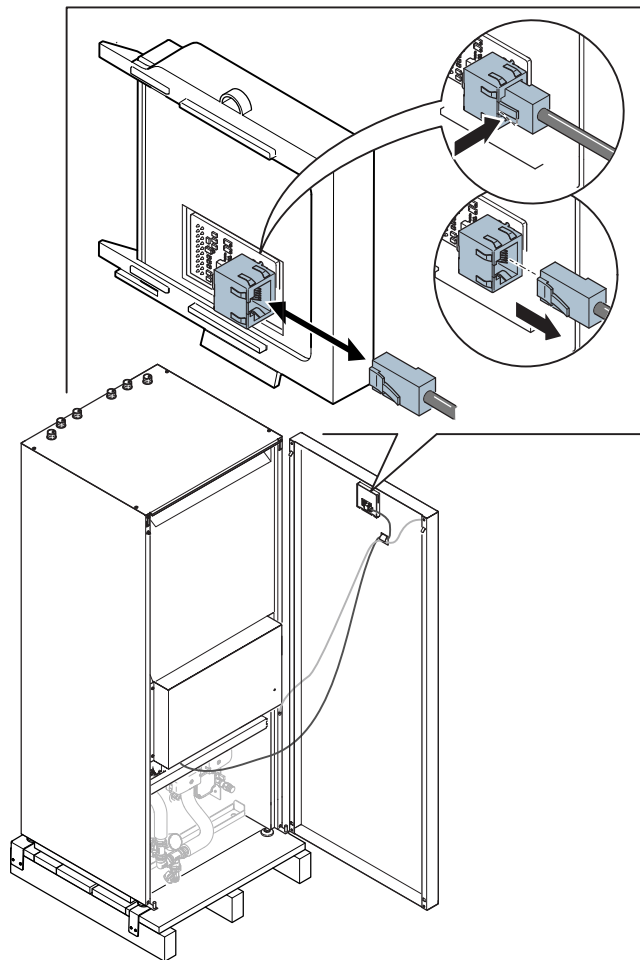

Disconnecting the display unit

The display unit is connected with an ethernet cable on the front cover. Remove the ethernet cable before moving the front cover too far away from the hydronic unit.

1. Press the tab on the ethernet plug.

Disconnecting the grounding wire

There is a grounding wire connected between the control box back panel and the front cover. Detach the wire connector from the fixing clip on the inside of the front cover.

- Grasp the clip with one hand and pull off the wire connector of the ground wire.

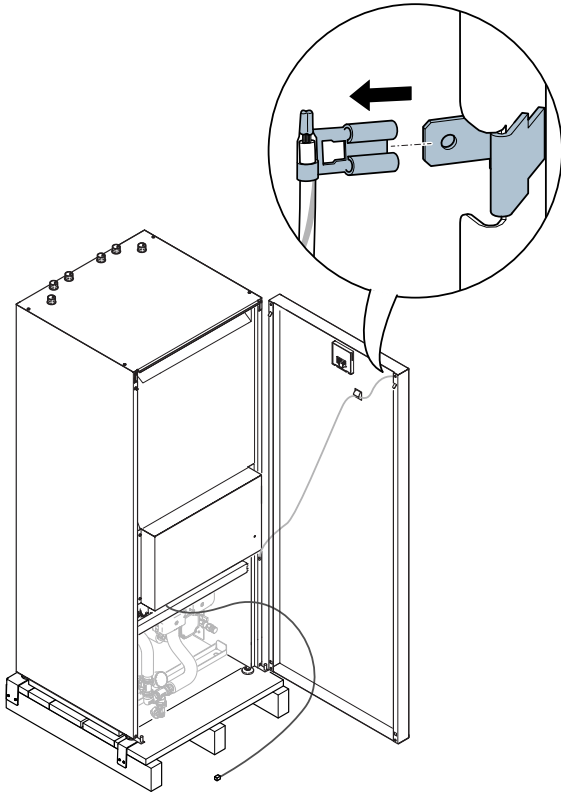

NOTE

After disconnecting the wire, move the front cover away from the product for safe movement.

Removal of pallet

1. Remove the four screws of the two reinforcement plates at the bottom of the frame from the front side of the product.
2. Remove the four screws of the two reinforcement plates at the bottom of the frame from the back of the product.
3. Remove the eight screws securing the reinforcement plates to the pallet.
4. Remove the front two reinforcement plates by moving them forwards.

5. Remove the rear two reinforcement plates by moving them backwards.

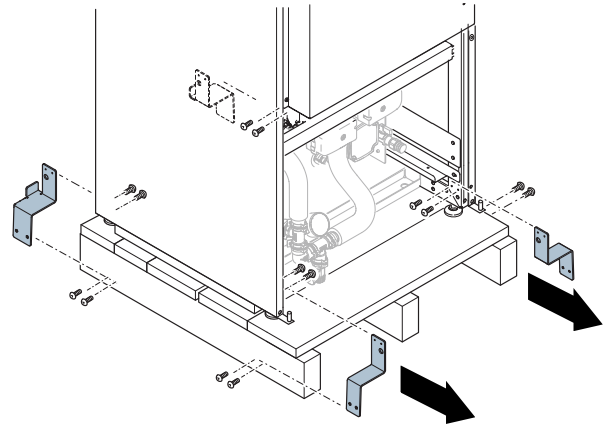

6. Remove the product from the pallet.
7. Remove the protective foil from the side panels.

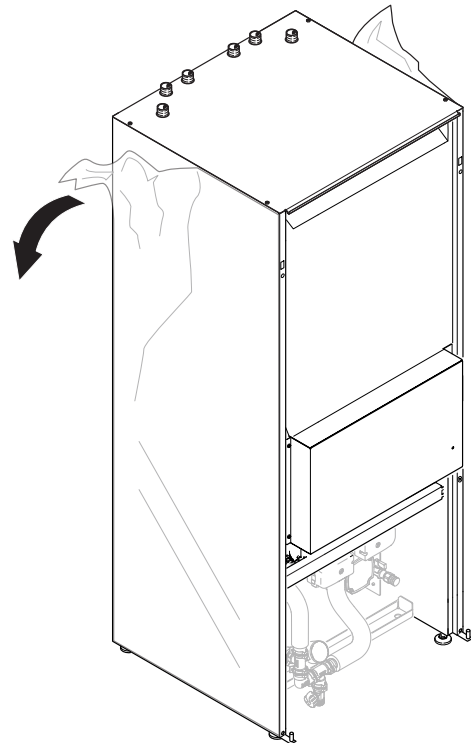

TIP

The transparent, protective foil covers all outside surfaces of the side panels.

Installation area

Ensure that the following installation area requirements are fulfilled.

- The foundation withstands the weight of the unit when it is filled.
- The foundation is waterproof and equipped with a floor drain.
- The area is frost-free.

i TIP

The feet under the unit must be adjusted to ensure that the product is stable and positioned in level. Use a wrench or a open end spanner (size 17) to adjust the feet.

- Distribution system refill hose
- Vent hose
- Snap-on ferrite core
- Cable with splicing connectors

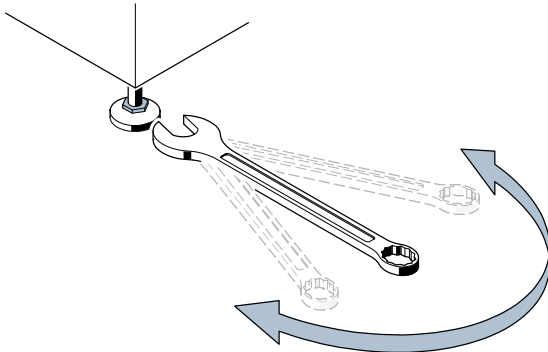

Setup dimensions

! CAUTION

A minimum of 800 mm free space must be available in front of the product.

The unit must not be placed in direct connection to the background wall or in connection to adjacent interior details as it can create unwanted noise. A minimum of 10 mm of clear space should be left behind and next to the unit.

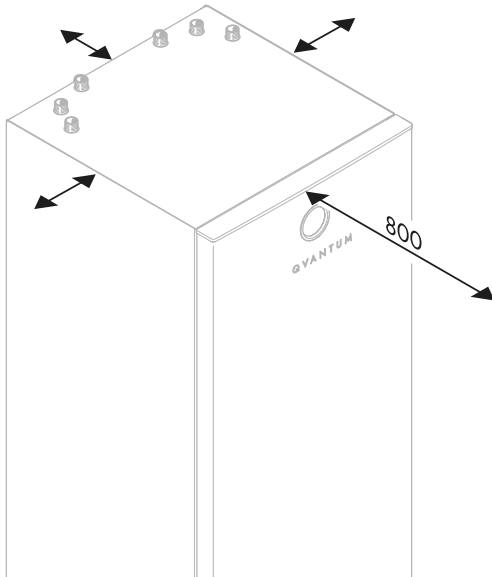

Additional components

Supplied components

The supplied components package contains the following items:

- Two filterball valves
- Indoor temperature sensor
- 3-pin busbar
- Outdoor temperature sensor
- Supply line temperature sensor

3 COMPONENTS

Overview

The Quantum QH is a hydronic unit that is primarily designed to be installed with a Quantum heat pump unit. The hydronic unit is connected to the facility's piping system through connections that are on the top of the unit.

Plumbing connections

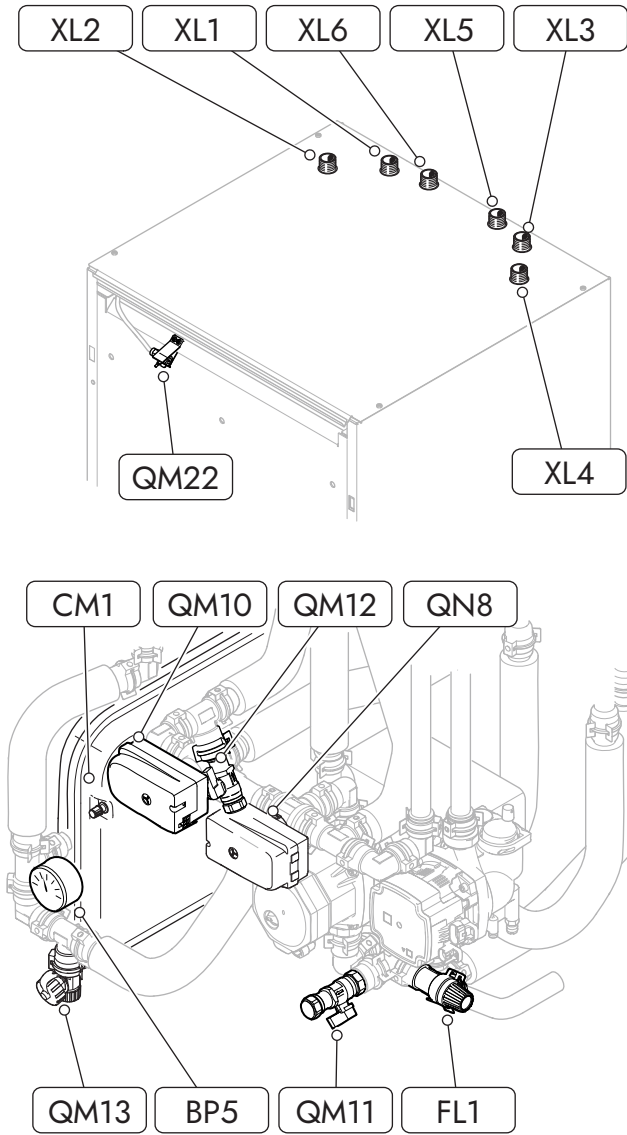

ID ¹	COMPONENT
BP5	Pressure gauge
CM10	Expansion vessel
FL1	Safety valve, hot water circuit
QM10	Diverting valve
QM11	Primary refill valve, distribution system
QM12	Secondary refill valve, distribution system
QM13	Drain valve, accumulator tank
QM22	Bleed valve, accumulator tank
QN8	Mixing valve
XL1	Connection distribution system, supply line

ID ¹	COMPONENT
XL2	Connection distribution system, return line
XL3	Connection, cold water
XL4	Connection, hot water
XL5	Connection heating medium, supply from heat pump
XL6	Connection heating medium, return to heat pump

¹ Component designations in accordance with IEC 81346.

Electrical box

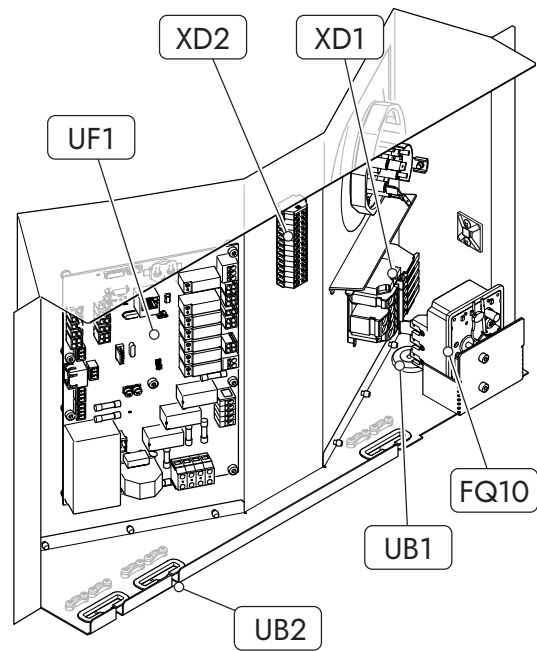

ID ¹	COMPONENT
FQ10	Safety temperature limiter (STL)
UB1	Cable entry, power supply
UB2	Cable entry, communication and sensors
UF1	Main board
XD1	Terminal block, power supply
XD2	Terminal block, communication and sensors

¹ Component designations in accordance with IEC 81346.

4 PIPE INSTALLATION

Pipe installation, general

NOTE

The pipe installations must be performed in accordance with applicable regulations.

All pipe connections face the top of the unit. The radiator system must be correctly adjusted so that the house has a balanced heat transfer.

CAUTION

The unit is not equipped with a safety valve for the distribution system. If installed without a Qvantum heat pump unit, ensure that an external safety valve for the distribution system is installed.

For best performance and operational reliability, the maximum allowed supply line temperature should not exceed 55 °C.

CAUTION

The temperature settings must be adjusted to accommodate the highest allowed supply line temperature of the distribution system. Not setting the correct temperatures can cause serious structural damage.

CAUTION

To avoid damage to components, ensure that the piping system is flushed out before connecting the heat pump.

CAUTION

If the unit is installed where a private well is used it may be necessary to add an extra water filter.

Operating principle

The hydronic unit gets the charge flow from the heat pump unit via XL5 (1). Depending on the demand, the heat is then distributed to heating or domestic hot water via a diverting valve QM10 (2). It will then be returned to the heat pump unit via XL6 (3) for collection of new energy.

If the compressor can not cover the demand in cold weather conditions, the mixing valve QN8 (4) starts to open, allowing additional heat stored in the accumulator tank to be distributed.

At this stage, the temperature in the tank will be maintained by the built-in immersion heater EB1 (5) which is switched on in stages as needed

Hot water circulation (6) is installed outside of the unit.

NOTE

The following image is a principle picture. The locations of components do not correspond with the actual product.

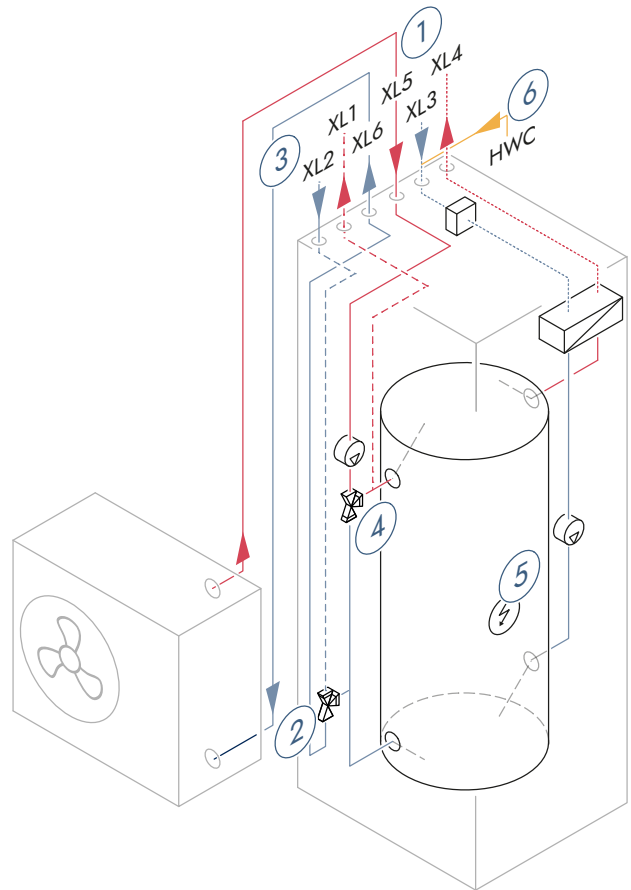

System volume

The expansion vessel (CM10) in the unit has a volume of 12 litres. The vessel has a pre-pressure of 1 bar. It is recommended that the height difference between the expansion vessel and the highest installed radiator does not exceed 7 meters ("Max" in the following image).

The height difference is measured between the center of the expansion vessel and the top-level radiator.

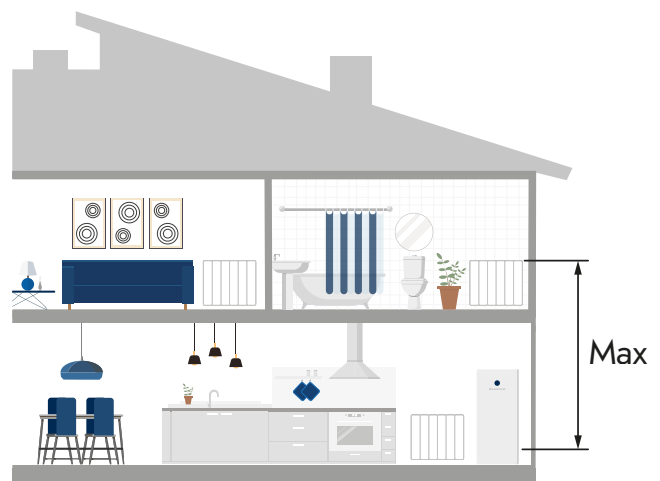

NOTE

If the pre-pressure is too low, the valve on the expansion vessel can be used for refilling of nitrogen. Changing the pre-pressure can affect the expansion vessel's capacity for accommodating the expansion of the water.

At the default pre-pressure of 1 bar, the maximum system volume is 230 litres.

Pipe connections

Measurements and dimensions

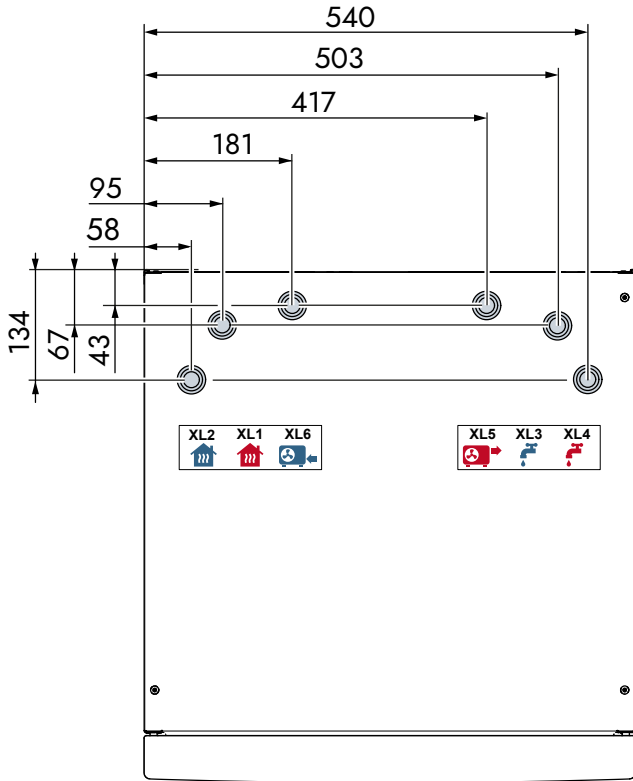

CONNECTION	DIMENSION
XL1, distribution system supply	DN20, external thread
XL2, distribution system return	DN20, external thread
XL3, cold water	DN20, external thread
XL4, hot water	DN20, external thread
XL5, outdoor unit supply	DN20, external thread
XL6, outdoor unit return	DN20, external thread

Installation

Standalone installation

This section applies to applications where the hydronic unit is installed without a Quantum heat pump unit, making the hydronic unit work as a standalone electric heating boiler.

The unit is not equipped with a safety valve for the distribution system. If installed as a standalone electric heating boiler, a safety valve with an opening pressure of 3 bar must be installed.

1. Mount a safety valve with an opening pressure of 3 bar between the docking pipe connections XL5 and XL6.

2. Bridge the docking pipe connections (XL5 and XL6).

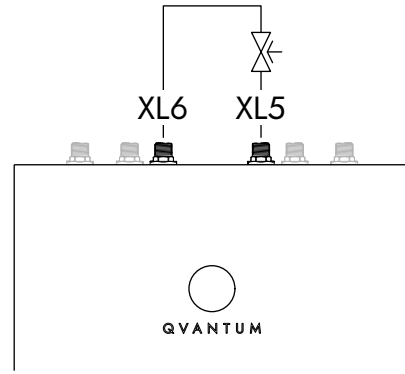

Distribution system

CAUTION

If the water in the distribution system is aggressive or lime-rich, use a water treatment additive to avoid damages to components.

NOTE

Ensure that sufficient system flow passes through the product. Fully opened thermostats helps maintain sufficient system flow and reduce the risk of operational disturbances.

The distribution system is used to accommodate the indoor comfort demands of the property. The control system adjusts to the comfort demands through heating suppliers, like for example radiators or floor heating.

- Connect the return line from the distribution system to the return connection (XL2).
- Connect the supply line to the distribution system to the supply connection (XL1).

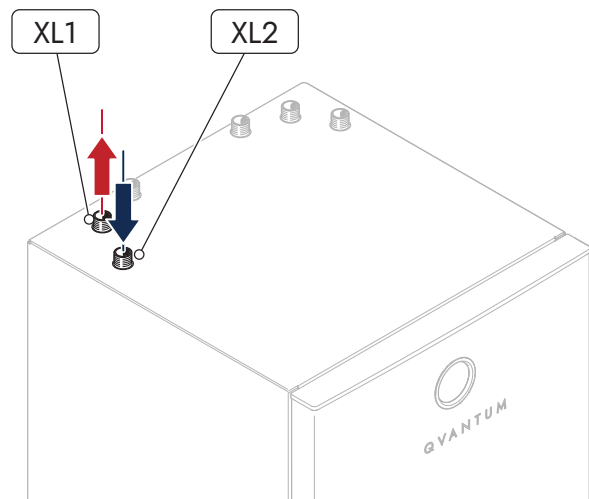

Overflow valve

In cases where the required flow is not obtained along the distribution system, an overflow valve can be installed. The overflow valve maintains circulation in the distribution system so that sufficient flow is maintained.

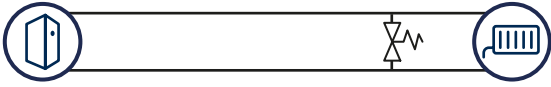

Cold and domestic hot water

- Attach the supplied filterball valve between the cold water main and the cold water connection (XL3).
- Connect the cold water supply to the cold water connection (XL3).
- Connect the domestic hot water system to the hot water connection (XL4).

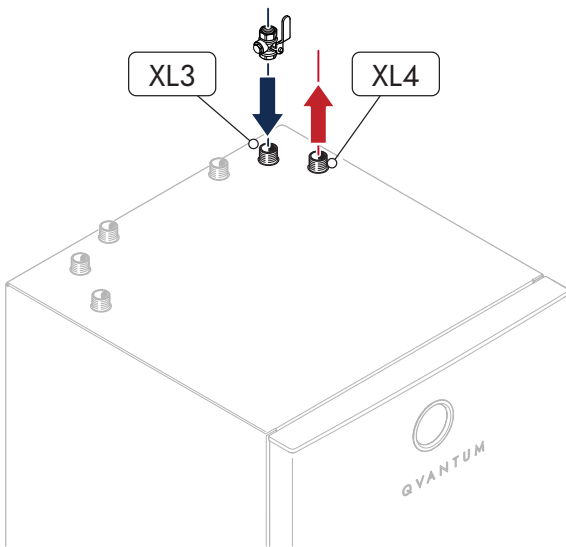

External water heater

If you need a higher volume and/or flow of domestic hot water, you can install an external water heater with the product.

Use an ESBE VTA353 mixing valve or an equivalent mixing valve when you install an electric water heater.

INSTALLATION WITHOUT HOT WATER CIRCULATION

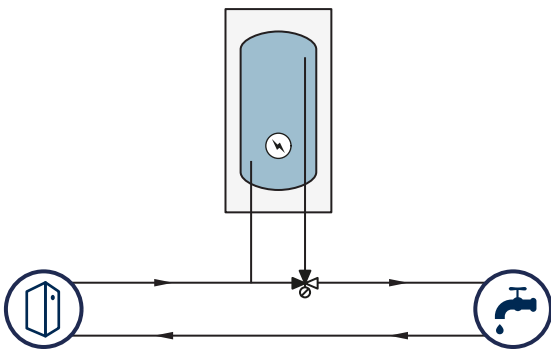

INSTALLATION WITH HOT WATER CIRCULATION

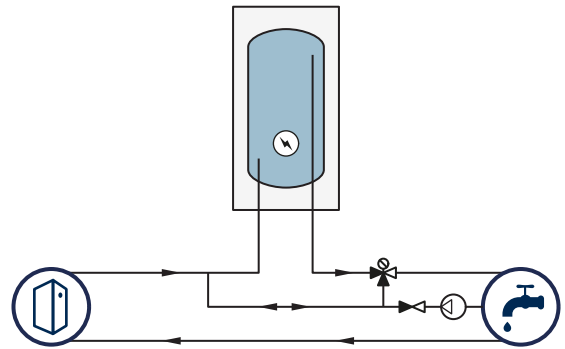

Heat pump unit

- Connect the heat pump unit's supply line to the heating medium supply connection (XL5).
- Attach the supplied filterball valve between the heat pump unit and the heating medium connection (XL6).
- Connect the heat pump unit's return line to the heating medium return connection (XL6).

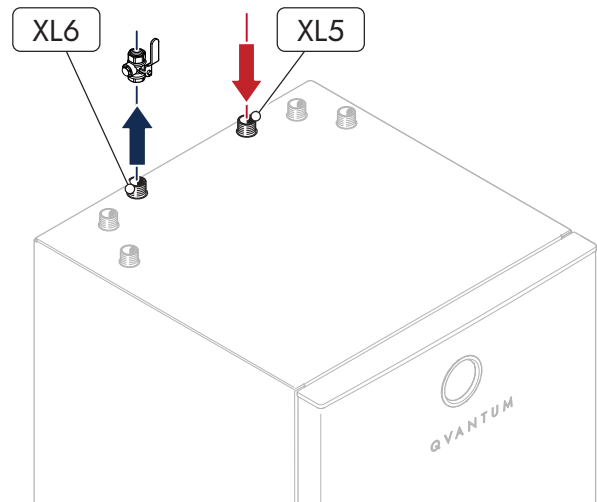

Safety valve discharge

If the safety valve for the hot water tank (FL1) opens, the water discharge runs through a pipe that faces the back of the product..

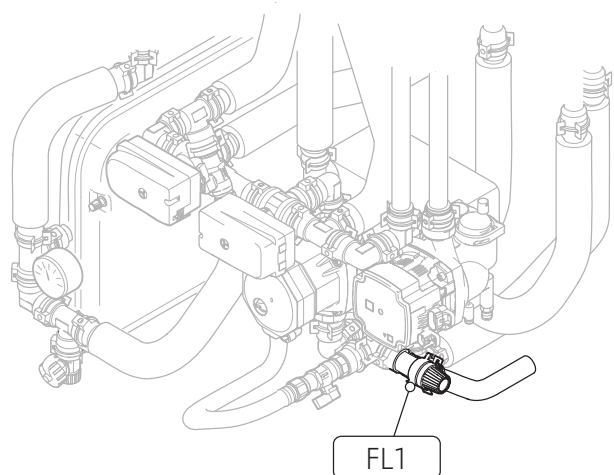

Connect the pipe from the safety valve to a floor or pipe drain.

i *TIP*

The safety valve can be turned to ensure that the inclination is sufficient.

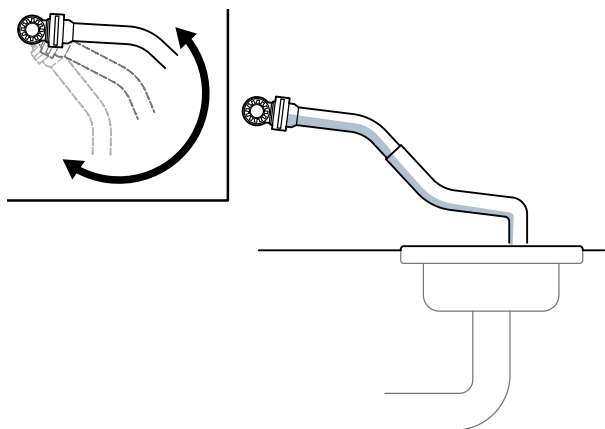

hand *NOTE*

The hose from the safety valve must be installed sloping along its entire length; water must be allowed to flow freely.

5 ELECTRICAL INSTALLATION

Electrical installation, general

⚠ WARNING

All electrical connections must be performed by a qualified electrician and in accordance with applicable regulations.

! CAUTION

Do not start the unit until it has been filled with water and all electrical connections have been checked. Premature start-up can cause damage to internal components.

- The unit must be disconnected before the house wiring is insulation tested.
- Power cables should be placed at least 200 mm from communication and sensor cables.
- It is recommended that the product is installed with a separate residual current device (RCD) with a tripping current of 30 mA.

Cable channels

The product has a cable gland (UB1) and a cable channel (UB2) that are used to reach internal electrical connections.

ID	CONNECTION TYPE
UB1	Power supply
UB2	Communication and external connections

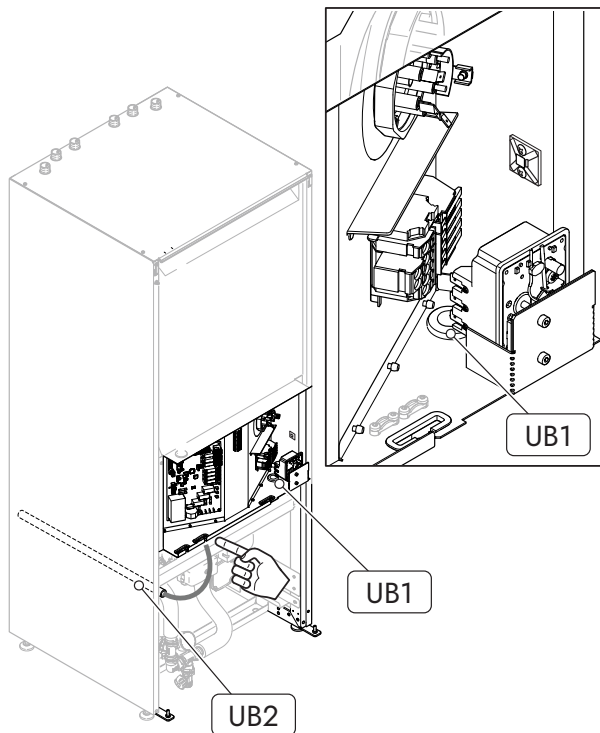

Access

Electrical box

The electrical box is located behind the front cover of the hydronic unit.

Remove the screws of the electrical box cover.

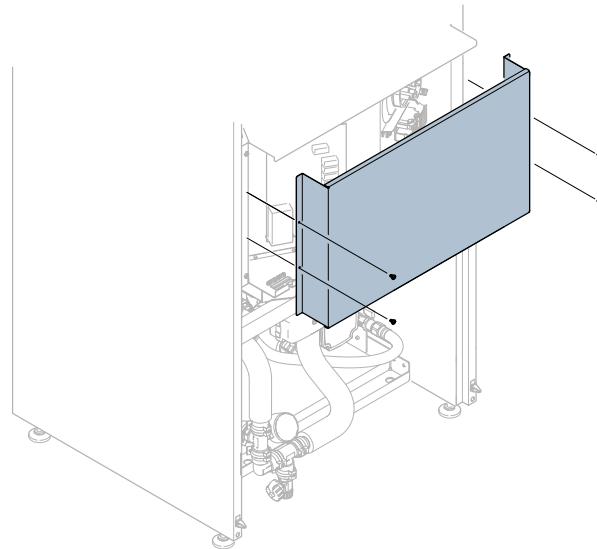

Fuses

The fuses are located on the circuit board (UF1) in the electrical box.

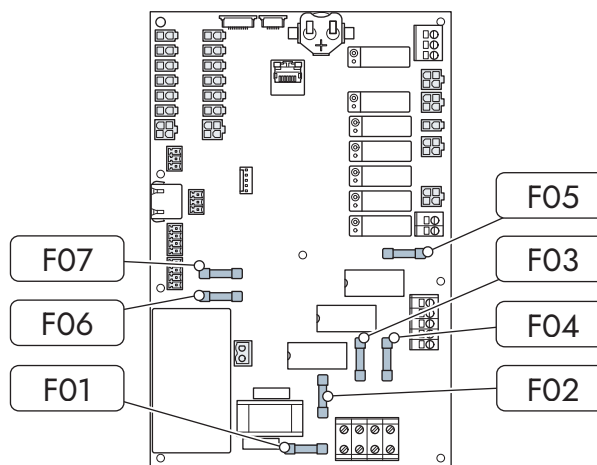

ID ¹	DESTINATION	FUSE TYPE
UF1:F01	Internal 230 V	4 A, 250 V
UF1:F02	Heat element (L1)	10 A, 250 V
UF1:F03	Heat element (L2)	10 A, 250 V
UF1:F04	Heat element (L3)	10 A, 250 V
UF1:F05	External 230 V	2 A, 250 V
UF1:F06	Internal 24 V	630 mA, 250 V
UF1:F07	External 24 V	500 mA, 250 V

¹ Component designations in accordance with IEC 81346.

Electrical connections

Power connection

The QH can be installed in single or three phase applications.

An isolator switch with a 3mm minimum breaking distance must be used to install the unit. Size the minimum cable area in accordance with the fuse rating that is being used. Dimension the fuse size according to the following table.

1X230V	3X400V
25 A (class C)	13 A (class C)

To connect the power supply, open the terminal block lever (1), insert the cable (2) and close the lever (3).

NOTE
The cable strip length should be 13–15mm.

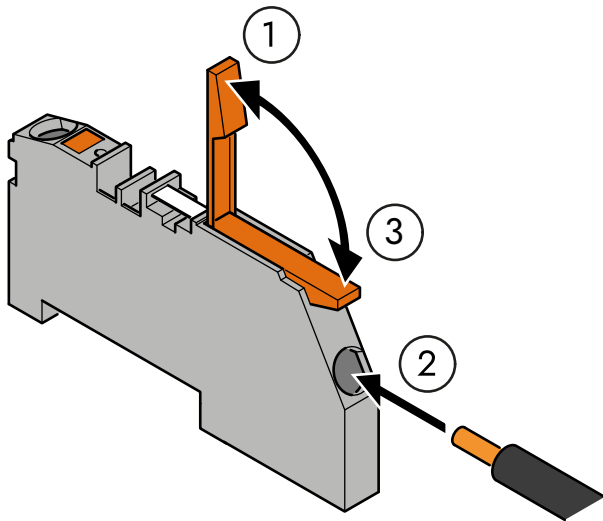

Cable routing

Route the power supply through the cable gland (UB1) at the bottom of the electrical box.

- Draw the cable through the cable rail at the bottom of the product.
- Secure the power cable on the cable rail. Use the supplied cable tie to secure the power cable on the cable tie anchor on the right-hand side of the electrical box.

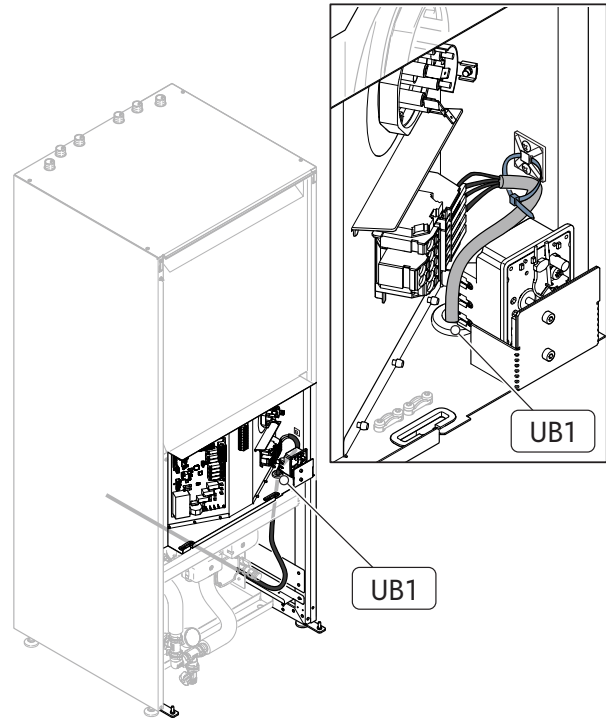

1x230V

For single-phase installations, the supplied 3-pin busbar must be used to bridge the phases on terminal block XD1.

1. Attach the supplied 3-pin busbar so it bridges connections XD1:L1, L2 and L3.

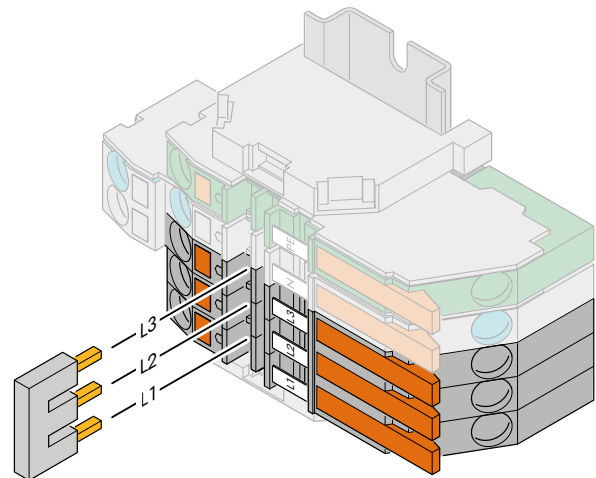

2. Connect the power supply to terminal block XD1.

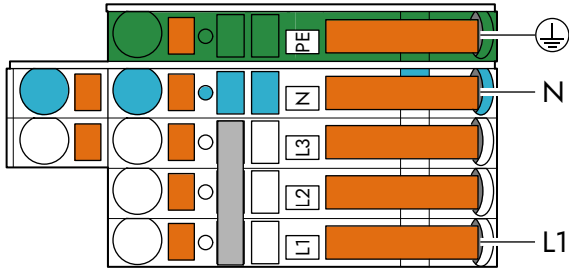

3x400V

1. Dispose of the supplied 3-pin busbar.

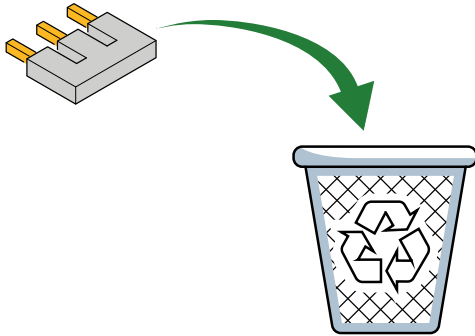

2. Connect the power supply to terminal block XD1.

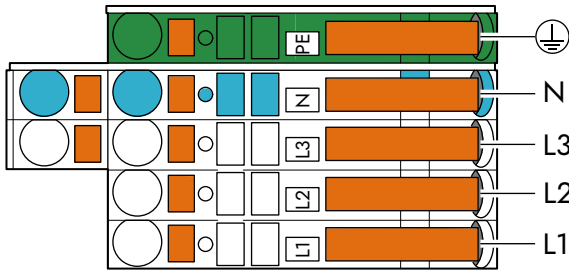

Communication with heat pump unit

Connect the communication from the outdoor unit to the MODBUS 3 socket on the main board (UF1). Grounding

of the communication cable is done through the grounding clip to the left of the main board.

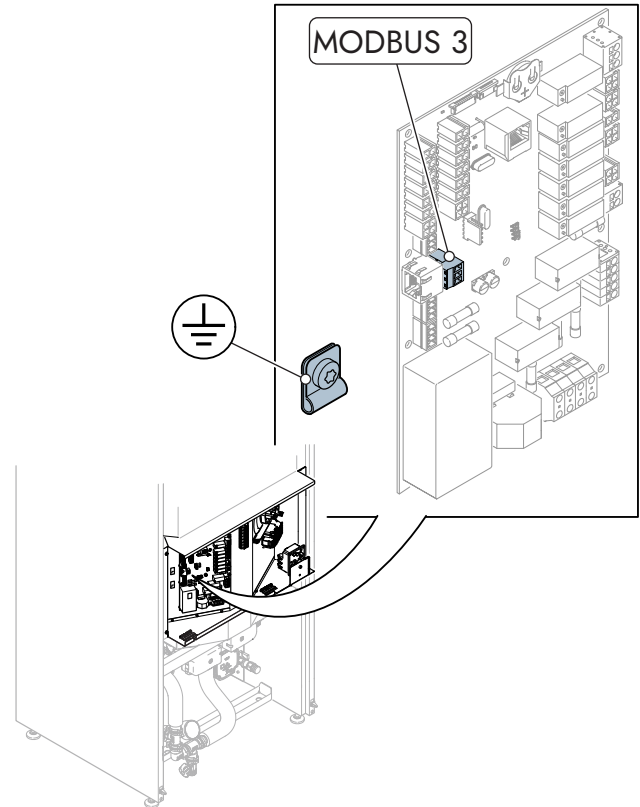

The communication cable should be of type S/UTP, S/FTP or equivalent twisted-pair cable with a braided shield.

Attach the exposed shield to the grounding clip.

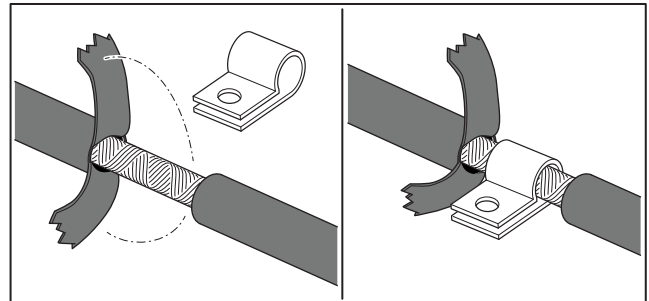

NOTE

Ensure that the shield has sufficient contact with the grounding clip.

NOTE

Do not connect the shield to the outdoor heat pump unit (QA).

1. Remove the connector from the MODBUS 3 socket on the main board (UF1).

2. Attach the wires to the connector.
 - a) Connect the communication wiring from the outdoor unit to UF1:MODBUS 3.

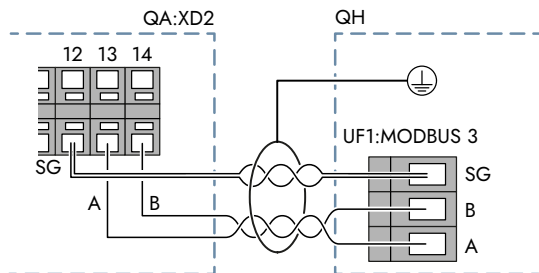

3. Reattach the modbus connector to the MODBUS 3 socket.

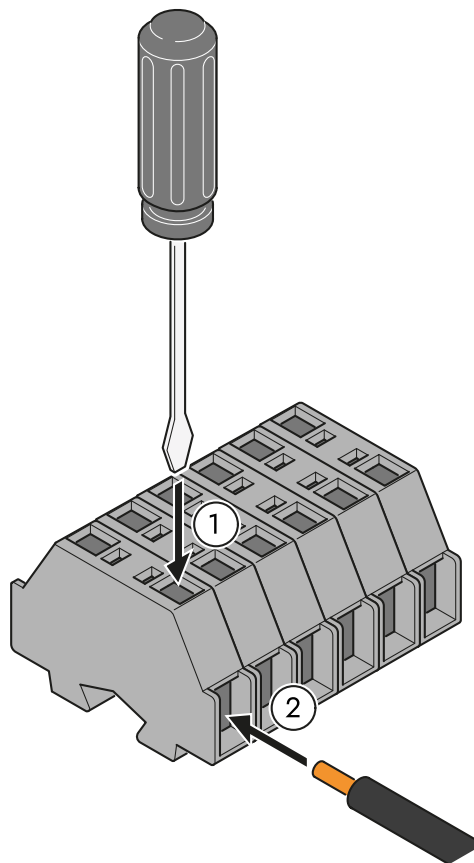
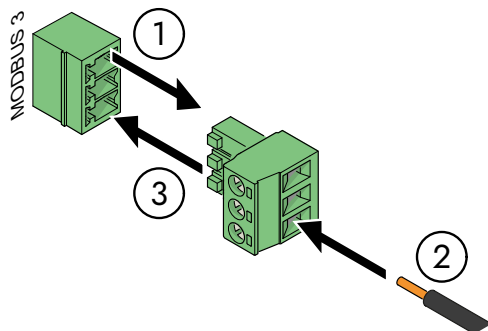

Sensors

The cables are connected to spring loaded terminal blocks on XD2.

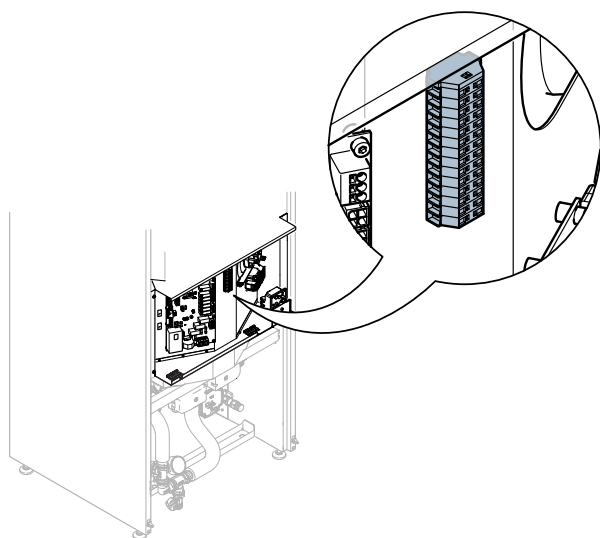

The cables should have an area of 0.5mm^2 with a cable length up to 50 m.

Connect the cables by inserting a screwdriver or similar at the top of the terminal block (1). When the spring in the terminal block is open, insert the cable (2).

Ferrite core

For electrical shielding purposes, all sensor cables should be routed through the supplied ferrite core (FE1).

The supplied ferrite core (FE1) must be placed outside of the QH. It is recommended that the ferrite core is mounted at the outlet of the cable channel for external connections (UB2).

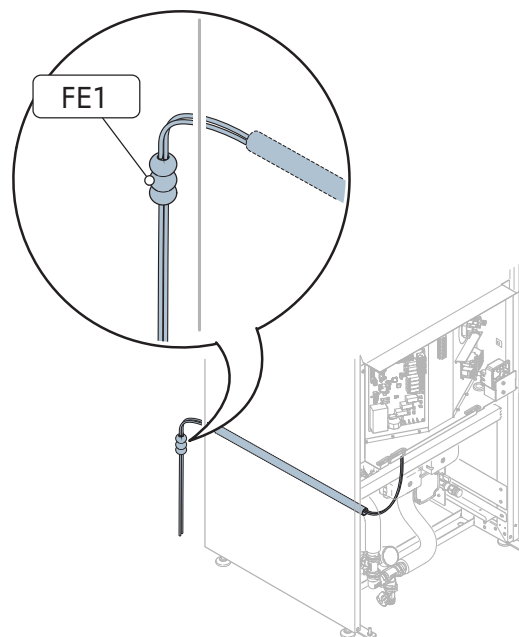

Outdoor temperature sensor

The outdoor temperature sensor (BT1) must be positioned so that it can give an accurate temperature reading. The sensor location should be protected from sun exposure and is preferably installed in a shaded area to the north or northwest.

To prevent condensation in the sensor chamber, seal the tube the cable is running through.

Route the cable through the supplied ferrite core (FE1).

Connect the outdoor temperature sensor (BT1) to terminal blocks XD2:1-2.

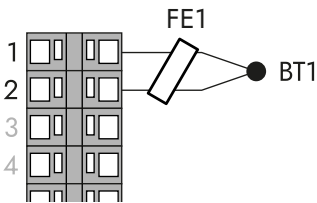

Indoor temperature sensor

The indoor temperature sensor (BT2) enables monitoring and control of the indoor temperature. Installing the indoor sensor is not mandatory, but necessary for reading the indoor temperature.

The sensor should be positioned so that it can give an accurate temperature reading, about 1.5 meters above the floor. Avoid placing it near heaters, radiators, windows, front doors, or anything else comparable. It must not be covered, exposed to air currents, or exposed to heat sources.

Route the cable through the supplied ferrite core (FE1).

Connect the indoor temperature sensor (BT2) to terminal blocks XD2:3-4.

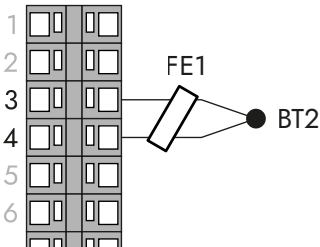

External supply temperature sensor

The external supply temperature sensor (BT12) enables monitoring and control of the external supply line temperature.

If an external supply temperature sensor is used, connect it to terminal blocks XD2:5-6.

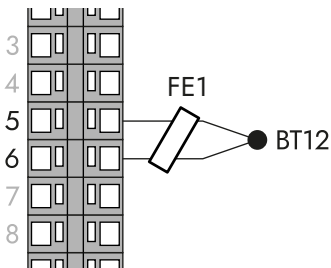

SG Ready

Enable the SG Ready function to allow the product to be controlled externally in support of the power grid. The states

of SG Ready A (SG A) and SG Ready B (SG B) are used to evaluate the demand from the power grid.

SG Ready is enabled through setting **SG Ready** in the start-up guide in the Qvantum app.

SG A	SG B	PRODUCT BEHAVIOR
0	0	The product is unaffected.
1	0	The product is blocked for a maximum of two hours per day.
0	1	The product is encouraged to run, e.g if the current price of electricity is low. In this mode, the set values for heating and production of domestic hot water are slightly increased. If there is no active demand, this mode will make the product encounter a new demand sooner than during normal operation.
1	1	The product is ordered to run. In this mode, the product always detects a heating demand and the set values for heating and production of domestic hot water are increased.

The function requires the connection of two potential-free contacts to the inputs UF1:BT4 and XD2:7-8 of the product. Use the supplied cable with splicing connectors to connect to input UF1:BT4.

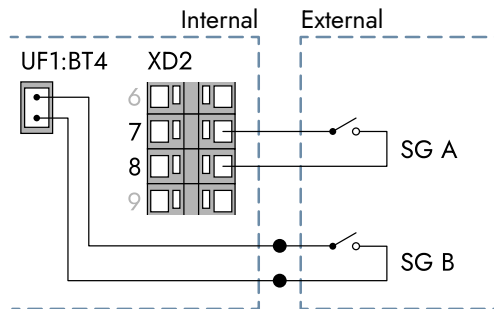

Safety temperature limiter

The unit is equipped with a safety temperature limiter that is behind the cover of the electrical box. If the temperature reaches 95 °C, the safety temperature limiter will stop the power to the immersion heater.

! CAUTION

Verify that the safety temperature limiter has not been triggered prior to installation.

A manual reset is required if the safety temperature limiter has been triggered. By pushing the button that can be accessed through a hole in the electrical box cover, the limiter is reset.

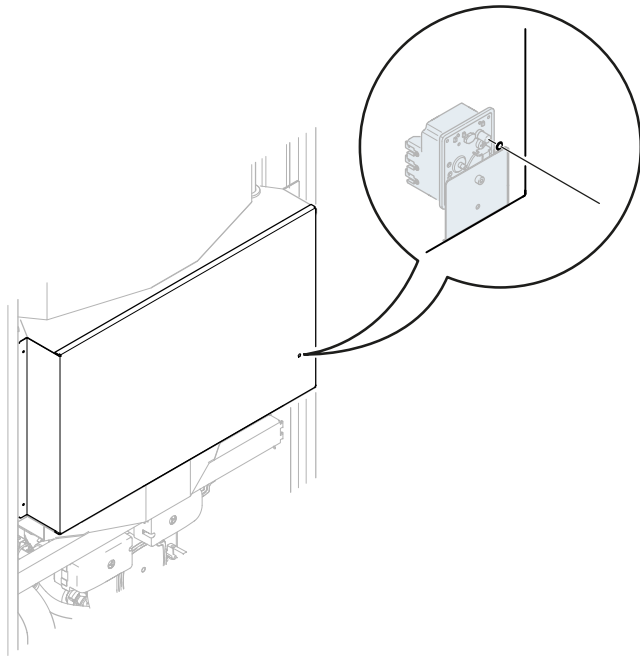

RELAY INDICATOR	STEP	OUTPUT
II, III	4	2 + 2 kW
I, II, III	5	1 + 2 + 2 kW

The installation checklist in the Quantum app allows you to set the maximum immersion heater output.

Settings

Immersion heater

The product has a built-in immersion heater. It turns on when the compressor cannot meet the current comfort demand.

Relays increase or decrease the immersion heater output in steps from 1 to 5. The **System overview** page shows an indicator for each active step. The indicators appear only when the immersion heater is active.

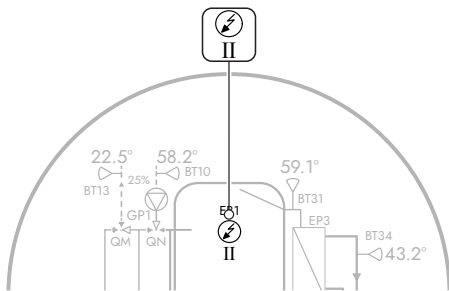

RELAY INDICATOR	STEP	OUTPUT
I	1	1 kW
II	2	2 kW
I, II	3	1 + 2 kW

6 COMMISSIONING

Quantum app

To properly set up the unit, install the Quantum app and follow the in-app instructions.

The app contains an installation checklist that helps you control all parts of the installation before starting the heat pump for the first time.

At first start-up of the unit, the app helps you set up the machine.

Installer mode

Setting up a unit requires setting the app to **Installer mode**.

1. Press the profile button in the upper right corner of the app.

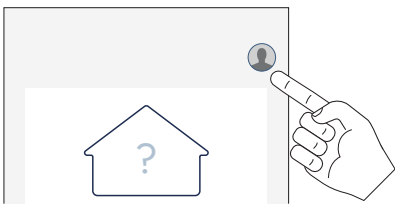

2. On the **Profile page**, scroll downwards.
3. Press the **Installer mode** button.

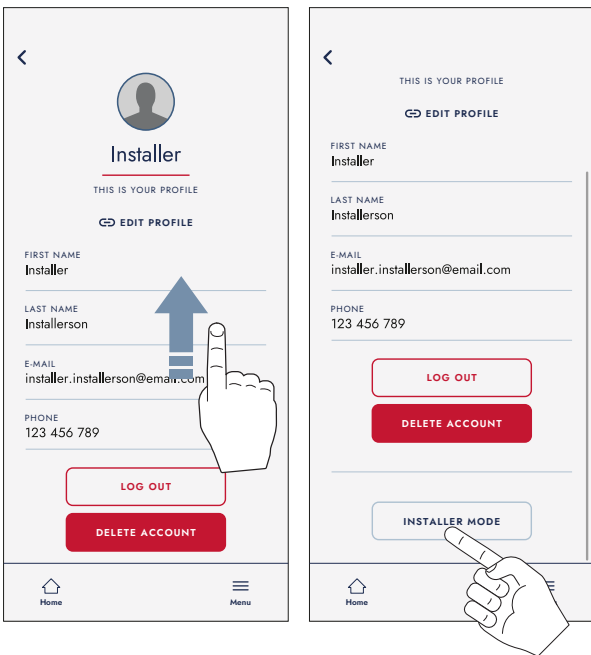

i TIP

If the **Installer mode** button is not visible, the app is already set to **Installer mode**.

Preparations

1. Ensure that the unit is turned off.

2. Ensure that the filling valves (QM11, QM12) are entirely closed.

h NOTE

The filling valves must be closed during normal operation.

h NOTE

The image shows the valves in closed position.

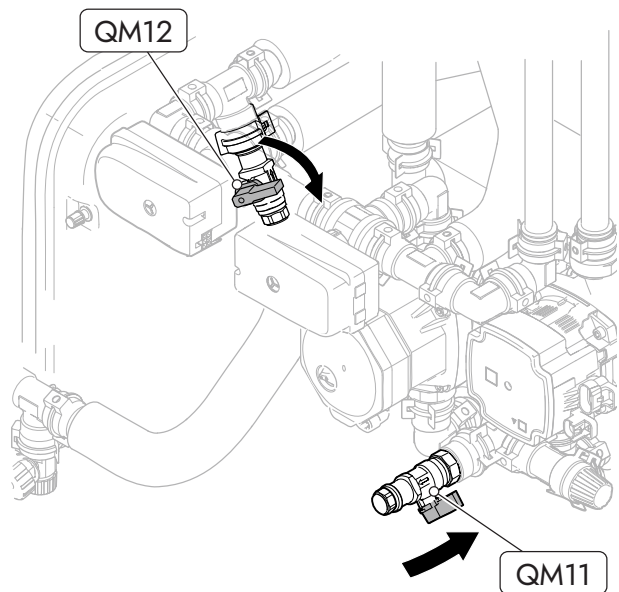

Filling hose

Before filling up the distribution and domestic hot water systems, the supplied filling hose must be attached to the filling valves (QM11 and QM12).

1. Remove the end caps from the filling valves.

i TIP

Use a wrench or similar to hold the affected valve in place.

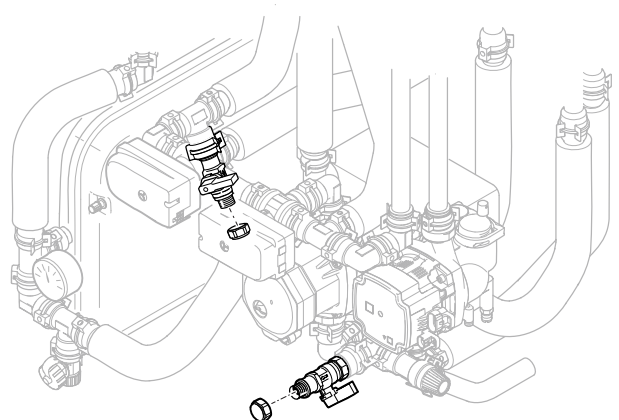

2. Attach the filling hose to the filling valves.

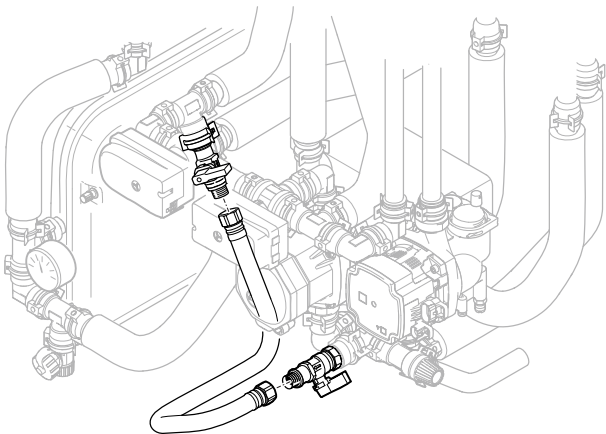

NOTE

After filling, remove the filling hose and reconnect the end caps.

Filling

Domestic hot water

1. Ensure that the filter ball valve that is connected to the cold water connection (XL3) is open.
2. Open one of the facility's hot water taps.
3. Open the facility's main cold water valve.

When no more air comes from the hot water tap, close the tap.

Distribution system

Attach a hose to the bleed valve before opening it.

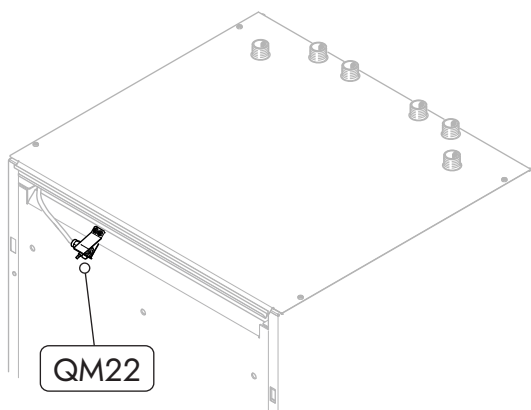

1. Power on the heat pump unit.
2. Open the bleed valve for the accumulator tank (QM22).
3. Ensure that the hose between the filling valves is securely attached.
4. Open the filling valves (QM11 and QM12)
The distribution system and accumulator tank will be filled with water.
5. Wait until air stops coming from the bleed valve (QM22) and close it.

6. Close the filling valves.
7. Reduce the distribution system pressure to approximately 1 - 1.5 bar.
 - a) Reduce the distribution system pressure by opening the bleed valves or the safety valve.
8. Start up the hydronic unit.
 - a) Allow the hydronic unit to run for one heating cycle and one hot water cycle.
9. Ensure that the hydronic unit provides room heating and hot water.
10. Open the bleed valve.
11. Wait for the bleed valve to be completely purged.
12. Close the bleed valve.

Venting

Distribution system

1. Turn off the unit and wait for at least 30 seconds.
2. Turn off the power supply to the unit.
3. Purge the unit by opening the bleed valve (QM22).
4. Refill and purge the distribution system until all air is removed and adequate system pressure is reached.

First start-up

CAUTION

Before the first start-up, ensure that there is no frozen water in the system.

NOTE

Before the first start-up, ensure that there is water in the distribution system.

NOTE

Set the app profile to **Installer mode** to set up the unit.

1. Turn on the system.
2. Open the Qvantum app.
3. Press **Install & set up unit** from the landing page.
4. Scan the QR code in the user interface.
5. Set up the system by following the steps shown in the app.
6. When all the steps in the app are completed, press **Finish installation** in the display unit.

To adjust the settings after the first start-up, use the display unit or the Qvantum app. The most common settings are available in both the display unit and the app. To access more advanced settings, the app must be used with the app profile set to **Installer mode**.

If the property is cool at commissioning, the internal additional heating might be activated to help the compressor satisfy the heating demand.

Pump capacity

The speed of the heating medium pump is adjusted through the Quantum app.

The speed settings **Pump speed heating** and **Pump speed idle mode** are available in the app.

Adjust **Pump speed heating** to set the pump speed for when heating is required.

Adjust **Pump speed idle mode** to set the pump speed for when there is no heating demand.

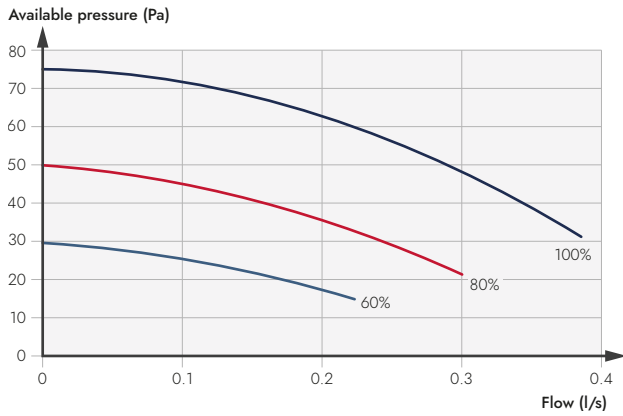

7 USER INTERFACE

Introduction

The Quantum QH is equipped with a user friendly touchscreen display. Through the display, the most necessary settings can be accessed and adjusted.

More settings are available through the Quantum app.

TIP

The layout of the display may vary depending on software version.

Using the display unit

Use the arrow buttons (1) on the sides of the interface to access the different pages in the display unit.

For display pages with settings, use the slider (2) at the bottom of the display to adjust the settings.

If an alarm is active, it is shown through a warning symbol (3) at the top of the page.

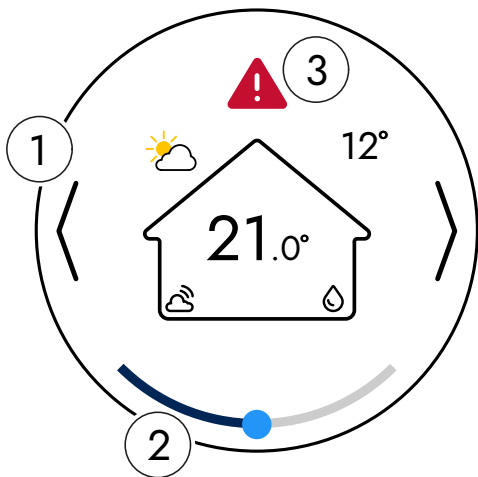

Swipe upwards and downwards or use the arrow buttons to access all content on display pages that contain multiple lines of information.

Indications

Different indicators are used to provide information to the user about the status of the product.

The middle area at the top of the screen shows if there are any active operational disturbances.

The lower left-hand corner of the house symbol shows connectivity-related information.

The lower right-hand corner of the house symbol shows what demand is prioritized by the product.

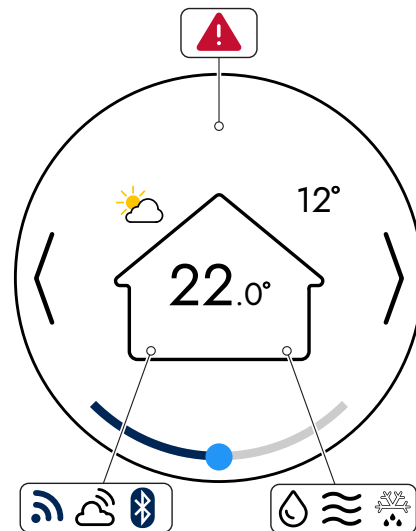

- Notification about an active alarm.
- Wi-Fi signal strength. The symbol is shown before the product is online.
- The product is online.
- Bluetooth connection established through the Quantum app.
- Domestic hot water production is active.
- Heating is active.
- Defrosting is active¹.
- 12°** Current outdoor air temperature.
- Weather indicator.

¹ Defrosting is only prioritized when the product is installed with a Quantum outdoor-air heat pump unit.

Indoor climate

The indoor climate is modified on the **Home page** of the display unit.

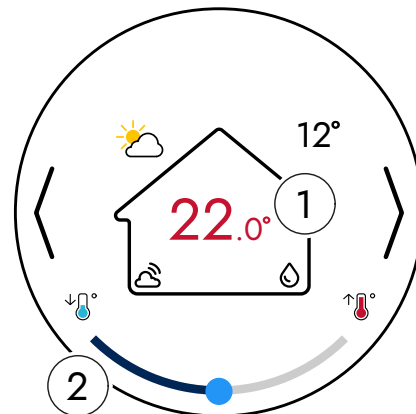

1. Desired or actual indoor temperature. If an indoor temperature sensor is set as the controlling sensor, the value inside the house is colored red when changing the setting.
2. Slider for adjusting the indoor temperature. Press the house icon to show the slider.

When adjusting the temperature, the value inside the house shows the desired value. A short time after the setting has been adjusted, the value in the house shows the actual temperature.

TIP

If an indoor temperature sensor is not present, the value inside the house shows the heating curve offset.

Temperature control

How the indoor temperature in the property is controlled depends on whether an indoor or outdoor temperature sensor is used for temperature control. If an indoor temperature sensor is not installed, or if it is only used for reading the indoor temperature, the temperature is controlled through the selected heating curve.

Select the controlling sensor through **Settings > Advanced > Temperature control**.

Indoor temperature sensor

When an indoor temperature sensor is set as the controlling sensor, the product compares the actual and requested indoor temperature to adjust the supply line temperature.

Heating curve

TIP

Selecting or setting up a manual heating curve is done when setting up the product during installation.

If an indoor temperature sensor is missing, or not set as a controlling sensor, the indoor temperature is controlled by the heating curve. The heating curve for the property is used to calculate the necessary supply line temperature at different outdoor temperatures.

When adjusting the indoor temperature, the heating curve offset shifts parallel downwards or upwards to decrease or increase the supply line temperature at a given outdoor temperature. The value inside the house on the **Home page** shows if the curve offset is shifted upwards or downwards, and with how many steps.

The following diagram shows the heating curve for a property with a radiator system and how the curve is affected by changing the offset.

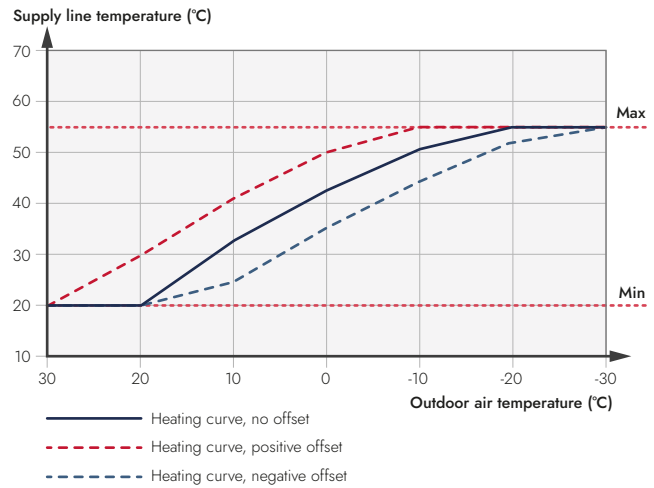

Domestic hot water

The page for domestic hot water is used to deliver information about the hot water production as well as modify the hot water capacity.

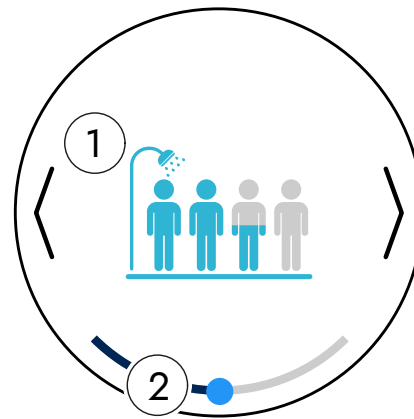

1. Indicator that shows the amount of remaining hot water. The number of characters depend on the requested hot water capacity. When the set temperature is reached, all characters are colored blue.
2. Slider for adjusting the hot water capacity.

Comfort and scheduling

The comfort and scheduling page is used to activate and control functions that accommodate needs that are outside of the heat pump's default operational modes.

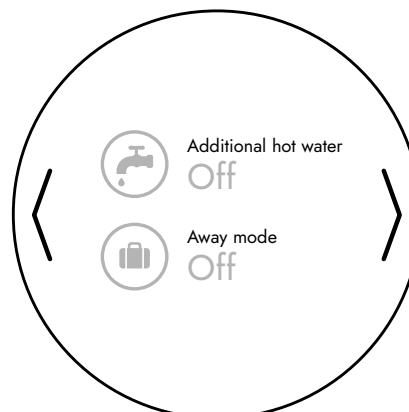

Additional hot water increases the hot water production for instances where additional hot water is desired.

NOTE

Depending on the current operating mode of the unit, turning on **Additional hot water** may also temporarily activate the immersion heater.

Away mode is a scheduling function that is useful when leaving the house for longer periods of time. When the away mode is activated, the heat pump lowers the indoor temperature and the hot water production.

Settings

The settings page has a number of sub pages that are used to retrieve product information, change display options, and configure heat pump performance.

Settings	Device information	Open-source code
	Recent alarms	
	Language	
	Service functions	Firmware update
		Purge air from system
		System overview
		Overrides
Advanced		Operation mode
		Temperature control
Turn device off		

Device information

This page contains product-specific information related to product identification, software versions and the Wi-Fi connection.

Open-source code

This page contains a link to a web page that lists all the open-source code licenses that are used for the user interface.

Recent alarms

This page gathers all recent alarms that have been detected by the product.

Language

Use this page to set the preferred language for the user interface.

Service functions

Firmware update

This page shows if there is an available firmware update for the main control board (UF1). If a newer version is available, press the button **Update main control board** to update the firmware.

Purge air from system

Use this page to temporarily turn off the heating medium pump before purging the distribution system.

Press the button **Turn pump off** to stop the heating medium pump.

After purging the distribution system, press the button **Turn pump on** to restart the heating medium pump.

If the **Turn pump on** button is not pressed, the heating medium pump will automatically restart after three hours.

System overview

The **System overview** in the display unit provides operational information for the product.

Exit the **System overview** by pressing the **Back** button.

Hydronic unit

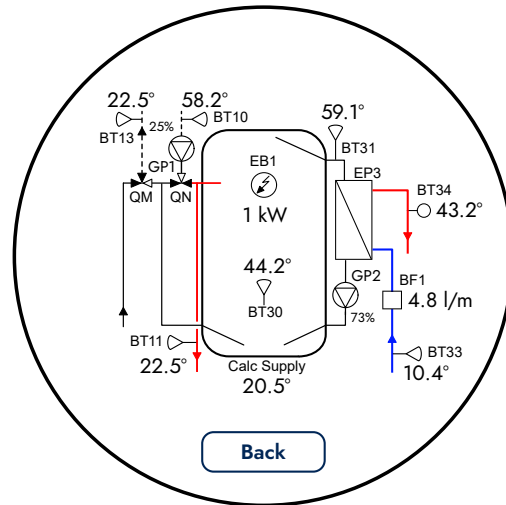

ID	DESCRIPTION
EB1	Immersion heater
EP3 ¹	Plate heat exchanger
Calc Supply	Requested supply line temperature
BF1	Flow sensor
BT10	Temperature, condenser out
BT11	Temperature, supply line
BT13	Temperature, condenser in
BT30	Temperature, buffer tank
BT31	Temperature, domestic hot water primary inlet
BT33	Temperature, cold water
BT34	Temperature, hot water
GP1	Circulation pump, distribution system
GP2	Circulation pump, domestic hot water
QM	Diverting valve
QN	Shunt valve

¹ Designation is not shown in the user interface.

Overrides

This page shows information about functions that are currently limiting the performance of the product.

Advanced

Operation mode

Through the **Operation mode** page it is possible to set the desired prioritization of the product. The main settings allow

the user to choose between automatic mode, manual mode and a mode where only electrical addition is allowed.

Auto

When the operation mode is set to **Auto**, the product automatically switches between heating and domestic hot water production, depending on the current demand. When in **Auto**, the electrical addition is engaged if necessary.

Manual

When the operation mode is set to **Manual**, it is possible to allow or prohibit heating and the user can choose to enable or disable the production of domestic hot water.

Manual mode allows for the user to enable or disable the use of electrical addition. If electrical addition is disabled, it is still allowed for production of domestic hot water and product protective functions.

Electrical addition only

This operation mode limits the product to run with only the electrical addition.

Temperature control

This page contains options related to the indoor temperature control.

Controlling sensor

Use this setting to declare what sensor is used to control the indoor temperature. Choose between the indoor temperature sensor (BT2) and the outdoor temperature sensor (BT1).

Compensation

The compensation function is only available when the indoor temperature sensor (BT2) is set as the controlling sensor. The compensation can be set to **Minimal**, **Normal** or **Maximal**.

The compensation controls the response time when a significant difference between the actual and the target indoor temperature is detected. If the compensation is set to **Maximal**, the response time is faster. If the compensation is set to **Minimal**, the response time is slower.

TIP

It is recommended to set a higher compensation in properties with high heat losses, e.g. older houses with poor insulation.

Shutting down the unit

The unit is shut down through **Extra settings > Turn device off**.

8 SERVICE

General

CAUTION

Maintenance and servicing must be performed by persons with sufficient knowledge about the task.

Remote service

This section explains how a home owner and an installer enable remote access to the product for service and troubleshooting.

The home owner must approve remote access before the installer or service technician can connect to the product.

Remote service allows a technician to troubleshoot or update settings without visiting the site. Access is granted through the Quantum app or the product's user interface. Remote access is time-limited and automatically expires after a certain period.

1. The installer opens the Quantum app and requests a service code from the home owner.

Navigate to: **Remote service**.

2. The home owner generates the remote service code.
 - a) Using the app: **Menu > Remote service**.
 - b) Using the user interface: **Settings > Service functions > Remote service**.

TIP

Through the app, the home owner can see which technicians have remote access and can revoke access for individual technicians.

3. The home owner gives the code to the installer.
4. The installer enters the code in the app.
5. The home owner grants access through the app or product interface.

The installer receives remote access to the product. The home owner is notified that remote access is active.

Maintenance

NOTE

The end user must be informed about necessary maintenance actions.

Filterball valves

The filterball valves should be cleaned regularly to prevent clogging.

Turn off the product before cleaning the filterball valves.

1. Close the filterball valve.

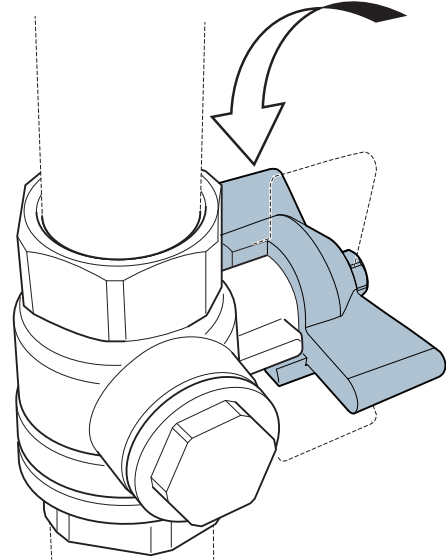

2. Remove the cap nut.

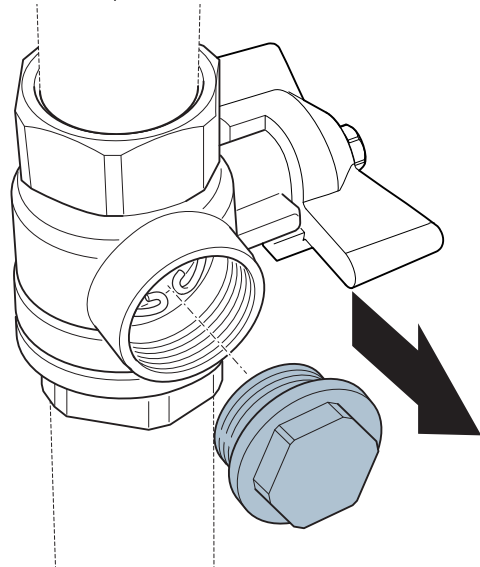

3. Remove the locking ring.

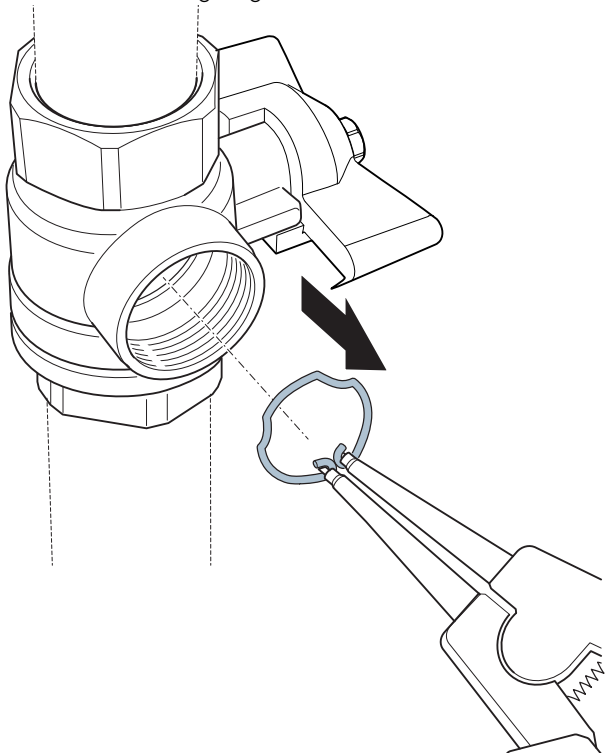

4. Remove the filter.

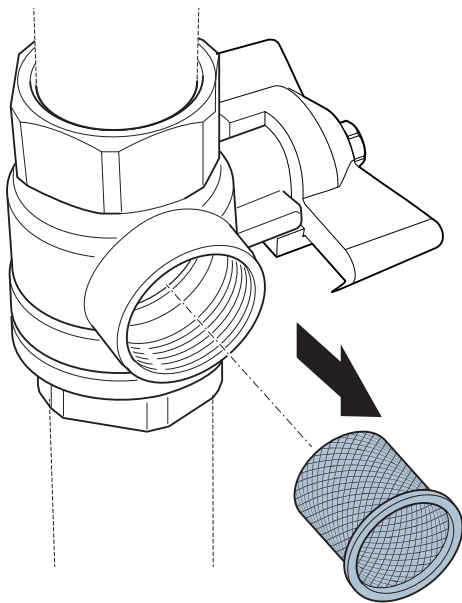

5. Clean the filter.

After cleaning the filter, reassemble the filterball valve and open it before turning on the product.

 **NOTE**

When reassembling the filterball valve, ensure that the locking ring is positioned properly.

Service actions

Draining the product

In case of component changes or if the heat pump must be moved, it might be necessary to drain the product of water. Emptying the accumulator tank is done through the tank drain connection (QM13). If necessary, rotate the drain valve by pulling it upwards or downwards.

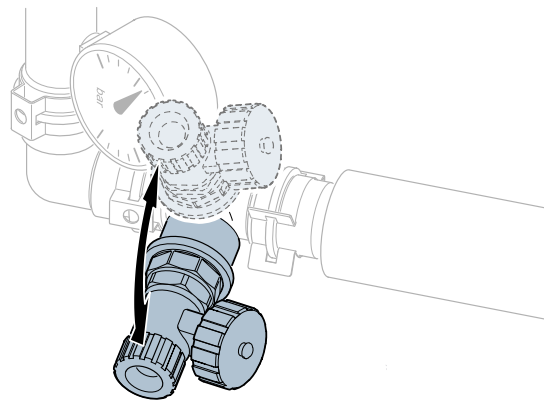

 **CAUTION**

Turn off the unit before draining the accumulator tank.

1. Remove the cap from the drain connection.

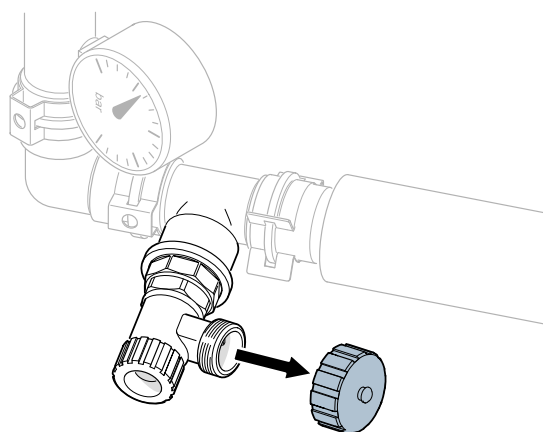

2. Attach a garden hose tap connector (1/2").

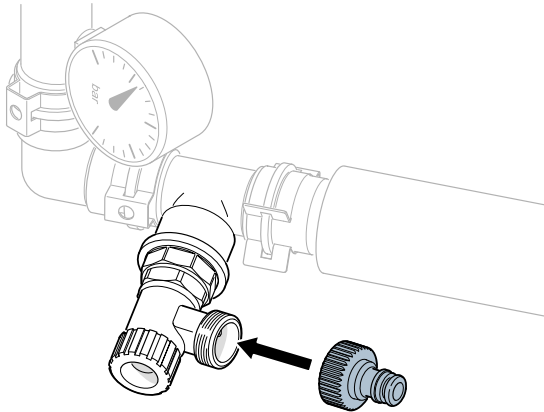

3. Attach a hose with a connector to the tap connector.

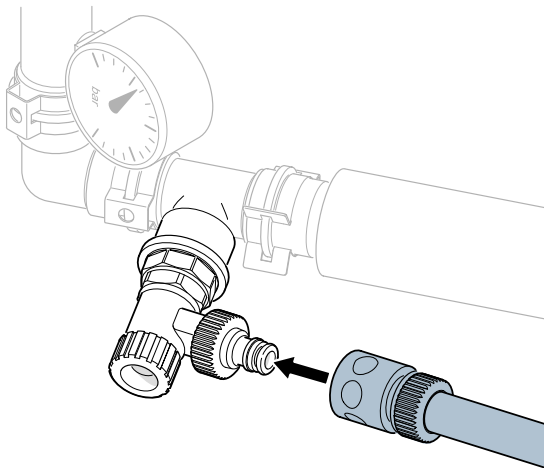

4. Open the drain connection by turning in counter-clockwise.

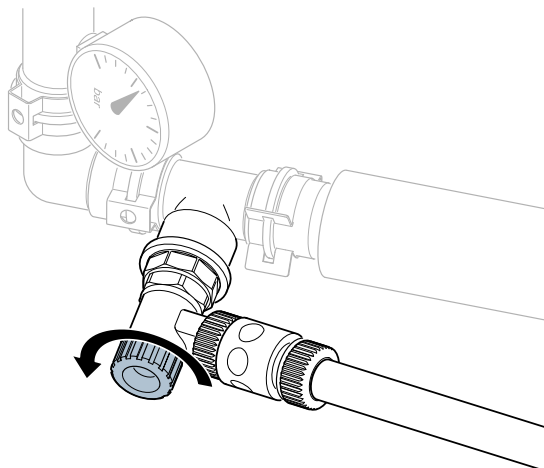

5. Open the bleed valve (QM22) for the accumulator tank.

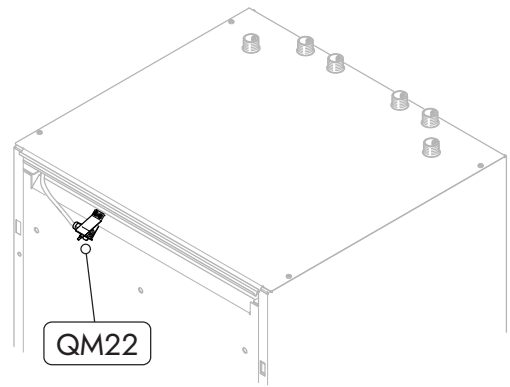

6. Remove the actuator from the diverting valve (QM10).
a) Pull the quick release lock (1) away from the actuator outlet.
b) Press the quick release ring (2).

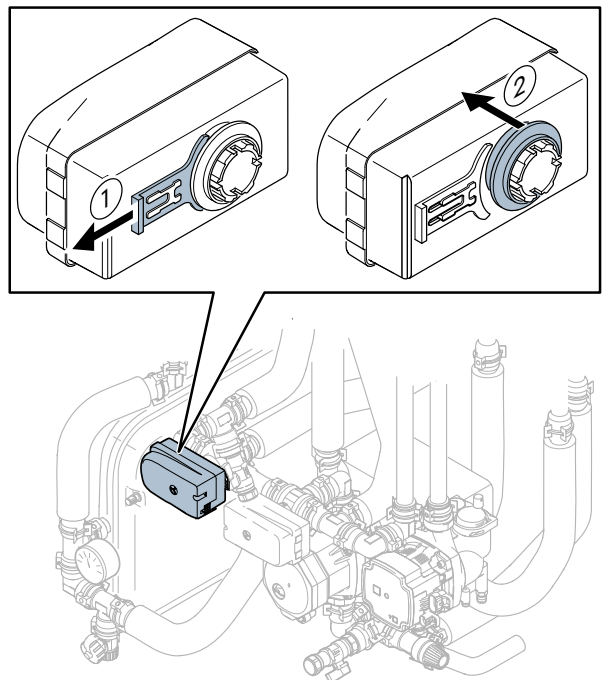

c) Remove the actuator (3).

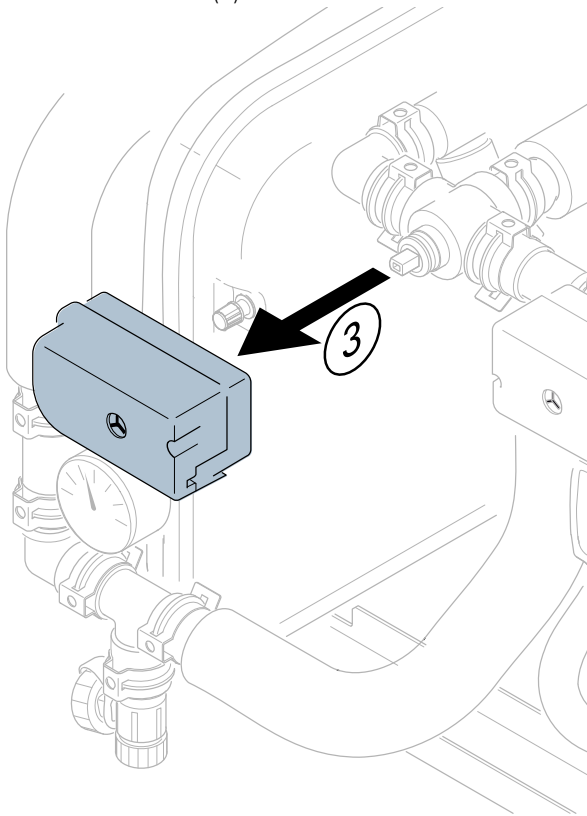

7. Turn the valve axle counter-clockwise (4) until the water starts flowing.

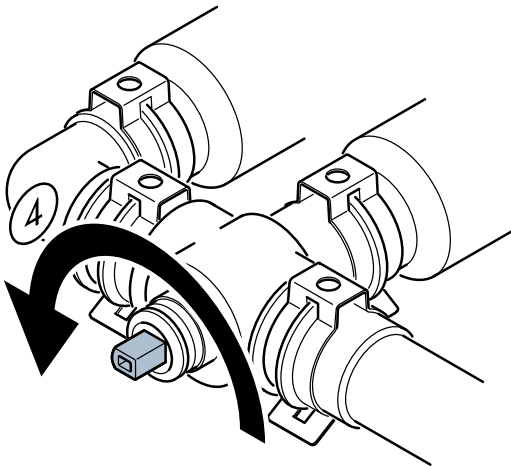

When water stops coming from the hose, restore the product to its original state.

- Close the drain connection
- Close the bleed valve
- Restore the diverting valve axle to the original position
- Reattach the actuator
- Remove the hose connectors
- Reattach the cap.

9 TROUBLESHOOTING

Before troubleshooting

If the system does not inform about an active fault, check the following components before troubleshooting:

WARNING

The incoming supply electricity must be isolated at the safety switch by or under the supervision of a trained electrician in the event that corrective action is needed to address faults that call for work inside screwed hatches.

- Power supply.
- Group and main fuses of the property.
- Residual current device (RCD).
- Internal fuses (F01–F08).
- Safety temperature limiter (FQ10).
- That the heat pump unit works as expected.

Low room temperature during heating

The room temperature is undesirably low when a heating demand is active

Closed thermostats

- Ensure that the thermostats are fully open. Keep in mind that individual thermostats can be turned down if a certain space needs to be cooler than the set target temperature.

Incorrect operational mode

- If operational mode **Auto** is active, set a higher value for setting **Stop heating**.
- If operational mode **Manual** is active, select **Heating**.
 - a) If selecting **Heating** is insufficient, enable setting **Allow additional heat**.

Too low target settings for automatic heat control

- Set a higher value for the offset heating curve.
 - a) If the room temperature is only insufficient in cold weather, increase the **Heating curve** setting with one step.

Away mode is active

- Turn off **Away mode**.

Heating medium pump(s) have stopped

- Check speed settings for circulation pumps.

Air in the distribution system

- Purge the distribution system.

Shut-off valve for heating medium supply is closed

- Open the shut-off valve for heating medium supply.

Allow addition setting is turned off

- Use the Quantum app and set **Allow addition** to **Yes**.

Too low value set for Allow addition temperature

- Use the Quantum app and increase the setting for **Allow addition temperature**.

Obstructed filterball valve

- Clean the filterball valve that is connected to the distribution system return line.

High room temperature during heating

The room temperature is undesirably high when a heating demand is active

Too high target settings for automatic heat control

- Set a lower value for the offset heating curve.
 - a) If the room temperature is only too high in cold weather, decrease the **Heating curve** setting with one step.

Incorrectly positioned indoor temperature sensor

- If an indoor temperature sensor is set as the controlling sensor, ensure that it is positioned so that a correct temperature reading is possible.

Insufficient hot water production

Lack of domestic hot water

Hot water demand is temporarily higher than in normal operation

- Temporarily increase the hot water production through setting **Additional hot water**.

Too low target temperature for hot water production

- Through display page **Domestic hot water**, increase the capacity for hot water production.

Faulty pipe installation

- Verify that the pipes for the hot and cold water connections are installed correctly.

The external mixing valve is set too low

- If present, verify that the mixing valve is set correctly.

Increased hot water consumption

- Wait until the domestic hot water reaches a sufficient temperature. The hot water production can be temporarily increased by activating the function **Additional hot water** for hot water capacity.

Low system pressure

Insufficient amount of water in the heating system

1. Purge the distribution system.
2. Refill the water in the distribution system.

10 TECHNICAL SPECIFICATIONS

Dimensions

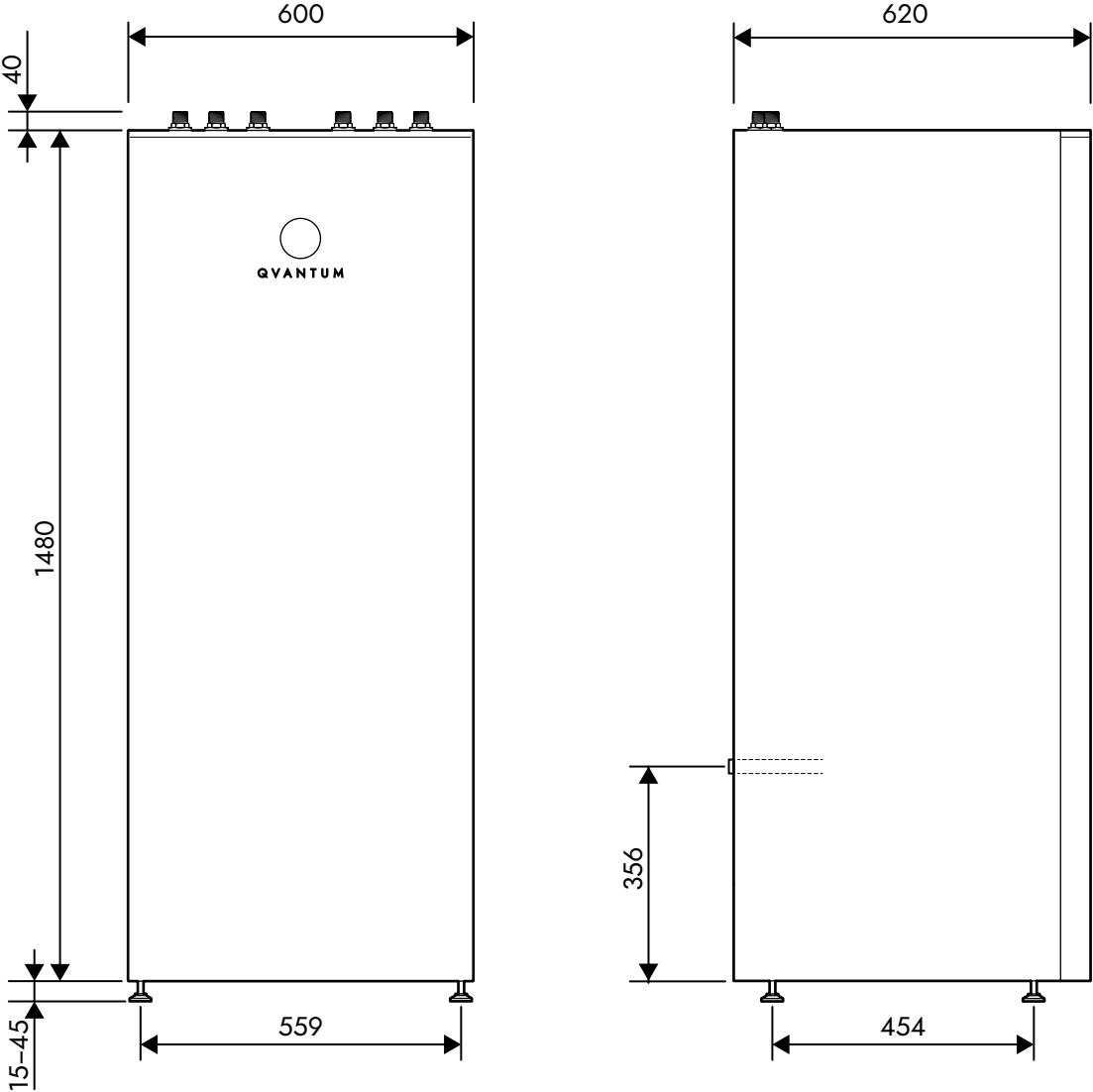

Technical data

MODEL		QH-175
Controller efficiency data		
Controller, class		VI
Controller, contribution to efficiency	%	4
Heating medium circuit		
Buffer tank volume	l	175
Opening pressure, safety valve ¹	MPa/bar	0.3 / 3
Max recommended temperature, supply line	°C	65
Max pressure, buffer tank	MPa/bar	0.3 / 3
Max temperature, buffer tank ²	°C	90
Hot water		
Plate heat exchanger volume	l	< 0.8
Opening pressure, safety valve	MPa (bar)	0.9 / 9
Amount of domestic hot water (40 °C) ^{3, 4}	l	230
Max amount of domestic hot water (40 °C) ^{3, 5}	l	350
Electrical data		
Rated voltage	V	400V 3N ~ 50Hz / 230V 1N ~ 50Hz
Max power immersion heater	kW	5.0 (1+2+2)
Maximum electric consumption, 3x400V / 1x230V	A	9 / 23
Recommended fuse, 3x400V / 1x230V	A	13 / 25
Recommended RCD type		A
Enclosure class		IP 21
Connection dimensions		
Distribution system, external thread		DN20
Cold water, external thread		DN20
Hot water, external thread		DN20
Heat pump, external thread		DN20
Weight and dimensions		
Weight, empty / filled	kg	110 / 285
Weight with packaging	kg	131
W x D x H	mm	600 x 620 x 1480
W x D x H with packaging	mm	661 x 680 x 1712
Service clearance height	mm	1715
Misc.		
Part no.		1003316

1 The safety valve is not present in the unit. Install a safety valve externally if the unit is installed as a standalone electric heating boiler.

2 With internal immersion heater.

3 At tap flow rate 10 l/min and an incoming cold water temperature of 10 °C.

4 When the setting for domestic hot water is set to four characters.

5 When operating mode Additional hot water is active.

Index

B

Before installing
Transport [7](#)

C

Communication with heat pump unit [18](#)
Components
Electrical box [11](#)
Fuses [16](#)
Overview [11](#)

E

Electrical connections [17](#)
1x230V [17](#)
3x400V [18](#)
Power connection [17](#)
Sensors [19](#)
Indoor temperature sensor [20](#)
Outdoor temperature sensor [20](#)
Electrical installation [16](#)
Access
Electrical box [16](#)
Communication with heat pump unit [18](#)
Safety temperature limiter [21](#)
Environmental information [5](#)

F

Front cover removal [7](#)
Disconnecting the display unit [8](#)

I

Important information
Environmental information [5](#)
Product labels [5](#)
Safety [4](#)
Serial number [5](#)
Installation area [9](#)
Setup dimensions [10](#)

O

Operating principle [12](#)

P

Pipe connections [13](#)
Measurements and dimensions [13](#)
Pipe installation [12](#)
Cold and domestic hot water [14](#)
Distribution system [13](#)

S

Safety temperature limiter [21](#)
Setup dimensions [10](#)
Shutting down the unit [28](#)
Supplied components [10](#)
System volume [12](#)

T

Technical specifications [34](#)
Dimensions [34](#)
Technical data [35](#)
Troubleshooting [33](#)
Before troubleshooting [33](#)

U

User interface
Settings
Service functions [27](#)

QCH EN 2537-A



1012215

This publication presents information that was valid at the time of publishing.
Quantum reserves the right to make changes without prior notification.
Subject to possible printing errors.
©2025 Quantum Energi AB

HEAT PUMPS FOR SUSTAINABLE CITIES

WE CHANGE THE WAY THE CITIES OF EUROPE ARE HEATED

Quantum, founded in Sweden in 1993, develops high-quality heat pumps for individual buildings and innovative heat pump-based solutions for densely populated areas to enable everybody to benefit from emission free heating and cooling. The company has deep knowledge in both heat pump technology and energy systems engineering and works in close collaboration with engineering consultants, installers, project developers and utilities.

Quantum Energi AB

Ji-te gatan 7, 265 38 Åstorp – Sweden | quantum.com



Q V A N T U M