

Quantum QA

Air-to-water heat pump



Installation and user handbook

QCH EN 2601-A
1013758

CONTENTS

1 Important information.....	3	Index.....	30
General.....	3		
Safety.....	3		
Symbols.....	4		
Product labels.....	4		
Product identification.....	4		
Product registration.....	4		
Environmental information.....	4		
Glossary.....	4		
2 Before installing.....	6		
Transport.....	6		
Installation area.....	6		
Additional components.....	7		
3 Components.....	8		
Overview.....	8		
Electrical box.....	8		
4 Pipe installation.....	9		
Pipe installation, general.....	9		
Pipe connections.....	9		
Preparations.....	9		
Installation.....	10		
5 Electrical installation.....	15		
Electrical installation, general.....	15		
Electrical connections.....	16		
6 Commissioning.....	19		
Before first start-up.....	19		
First start-up.....	19		
Compressor preheating.....	19		
7 Service.....	20		
General.....	20		
Maintenance.....	20		
8 Troubleshooting.....	21		
Before troubleshooting.....	21		
The heat pump does not start.....	21		
No communication with hydronic unit.....	21		
Insufficient hot water production.....	21		
Low room temperature.....	21		
High room temperature.....	21		
Frost build-up on evaporator.....	21		
Abnormal noise.....	22		
9 Technical specifications.....	23		
Sound levels.....	23		
Dimensions.....	23		
Operational data.....	23		
Technical data.....	25		
Energy labelling.....	26		

1 IMPORTANT INFORMATION

General

⚠ WARNING

Read this manual before starting the unit for the first time.

It is the owner of the product that is responsible for the system. If you suspect that the product is defective, contact your dealer.

i TIP

For the latest available product documentation, visit quantum.com.

Safety

This appliance can be used by children from 8 years and above and people with reduced physical, sensory or mental capabilities or lack of experience and knowledge if they have been given supervision or instruction concerning the use of the appliance in a safe way and understand the hazards involved. Children must not play with the appliance. Cleaning and maintenance must not be performed by children unless they are older than 8 and supervised.

The manual must be available for people who install, support or use the product.

Work must follow the instructions described in this manual. Companies and persons installing and maintaining the product must have the required certificates, licenses and qualifications.

The work must comply with current regulations and practices and be carried out professionally.

When powering up the product, there must be no frozen water in the system.

Wiring and electrical installation must be performed in compliance with national regulations.

It must be possible to safely disconnect the electrical power supply to the unit. Install the power supply with an isolator switch and size the cable area based on the fuse rating that is being used.

R290 refrigerant

R290, a flammable refrigerant, is present in the product. In the event of a leak, leaking refrigerant might combine with air and create an environment that could catch fire.

⚠ WARNING

It is prohibited to expose the product to flammable gases or liquids as it may cause fire.

⚠ WARNING

The unit must not be placed close to flammable gas. Fire may start if there is a gas leak of any kind.

⚠ WARNING

Do not use means to accelerate the defrosting process or to clean, other than those recommended by the manufacturer.

Safe area

⚠ WARNING

The heat pump must be installed outdoors. The unit must be installed so that, in the event of a leak, refrigerant cannot enter the building.

Vertically, the safe area stretches from the top of the product to ground level (H1 in the following image).

From the top of the product, the safety zone extends 0.5 m from the product's outer edges.

At ground level, the safety zone extends one meter from the product's outer edges.

👉 NOTE

The safe area is not to be mistaken for the allowed installation area.

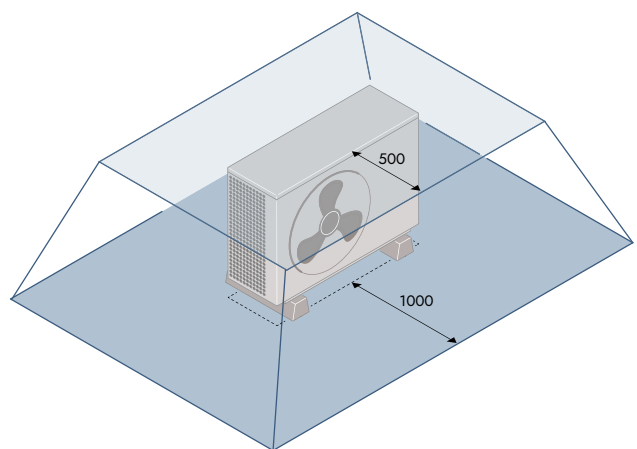

Windows, doors, ventilation openings, and potential ignition sources must not be present in the safe area. The safe area extends into neighboring structures. All wall penetrations in outer walls must be gas-tightly sealed.

Symbols

The manual contains the following symbols

WARNING

This symbol describes information that is of great danger to people or equipment.

CAUTION

This symbol describes information that could cause danger to people or equipment.

NOTE

This symbol describes information that is crucial when installing or servicing the product.

TIP

This symbol describes information that can be helpful when installing or servicing the product.

Product labels

These labels are found on the product.

CE CE marking indicates that a product has been assessed by the manufacturer and deemed to meet EU safety, health and environmental protection requirements.

IPX4 Protection classification against water and dust in the electrical enclosure.



Warning label that indicates that the product contains flammable material.



Warning label that indicates that open flames or other ignition sources are prohibited.



Read the supplied documentation.



Read the supplied documentation.

Product identification

The product identification label is visible on the right-hand side of the product.

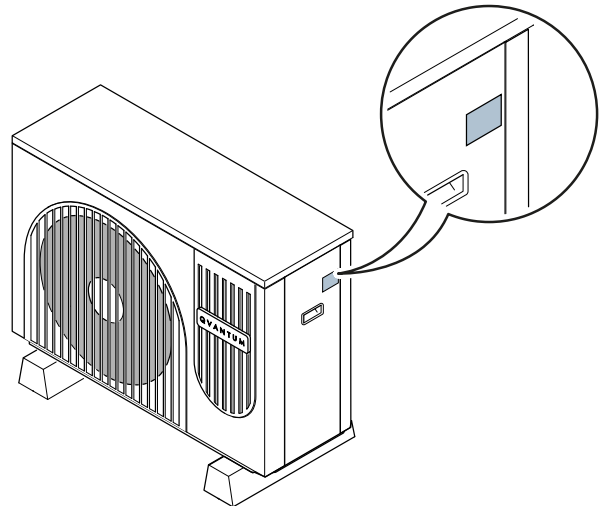

Product registration

The product must be registered for the warranty to take effect. The product can be registered no more than 12 months after the delivery date from the factory and no more than one month after the installation. If the product is registered at a later stage, the warranty period will be affected.

The product registration is done as part of the start-up guide in the Quantum app when setting up the Quantum hydronic unit.

Environmental information

Recycling



At the end of the electrical products useful life, it must not be disposed of with household waste.

Recycle at waste facility. Check with your local authority or retailer for local recycling regulations.

Packaging content

The product packaging contains the following materials.

MATERIAL		QA-9	QA-15
Cardboard	kg	6,5	9,2
Plastic	g	80	80
Wood (pallet)	kg	13,5	15,7
Metal	g	5	5

Glossary

The following terms are used throughout the manual to describe various functions of the product.

Distribution system

The distribution system is the system that is used to provide the house with heating through radiators, floor heating and/or fan convectors.

Hydronic unit

The hydronic unit consists of an accumulator tank, pipe connections, electrical connections and the graphical user interface. It provides the house with domestic hot water as well as heating through the distribution system.

Heat pump unit

The Quantum QA is a heat pump module that is placed outside of the facility. It draws heat from the outdoor air and transfers it to a hydronic unit.

2 BEFORE INSTALLING

Transport

Transport the product in an upright position. Ensure that the product is adequately secured so it does not fall down during transit.

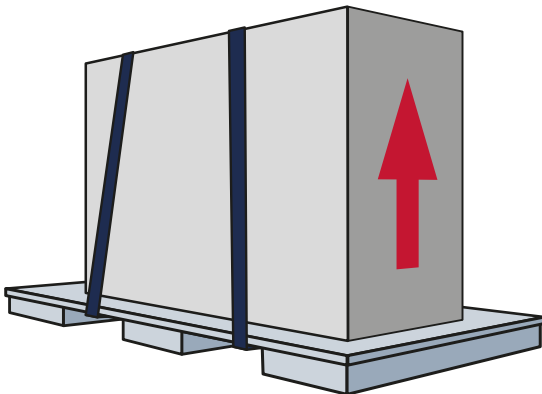

At arrival, ensure that the product was not damaged during transport.

If using a trolley or hand truck when moving the product, always have the product standing on the pallet.

Installation area

Measurements

When installing the unit, ensure that there is enough room for the inlet and outlet air. There must be at least 300 mm of free space behind and 1500 mm in front of the heat pump.

For service, keep at least 1000 mm of free space on the right, 500 mm on the left, and 600 mm above the heat pump.

NOTE

Consider the height of obstacles surrounding the heat pump. High walls or other barriers can cause resonant sounds and unwanted recirculation of cold air.

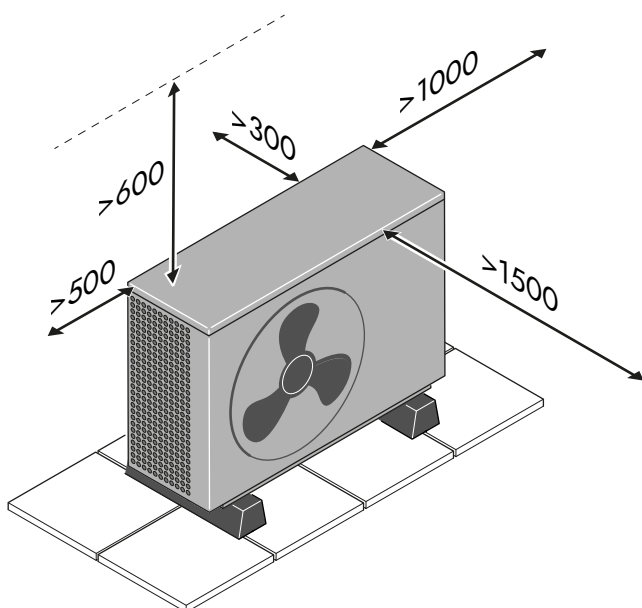

Prerequisites

Install the heat pump in accordance with the following requirements.

NOTE

If the heat pump is placed on concrete slabs, the slabs must rest on shingles or asphalt.

Place the heat pump on a solid surface that can withstand the weight of the heat pump.

- a) Do not place the heat pump directly on a lawn or a similar non-solid surface.
 - b) Place the heat pump on a concrete base, concrete slabs or equivalent.
- Ensure that the heat pump is level.

NOTE

If the heat pump cannot be installed level, the lowest point must be at the condensation water outlet.

- Ensure that the installation area is adequately ventilated.

NOTE

In case of leakage, the refrigerant must not enter the house through ventilation openings, doors or windows.

- Direct wind can reduce the performance and defrosting of the product. Install the product in a place protected from direct wind.
- Ensure that the installation area is free from heat radiation, fire hazards and ignition sources.
- Do not position the heat pump next to a noise sensitive wall.
- Ensure that condensing water is drained away from the heat pump.
- Ensure that the heat pump is protected from snowfall and kept free from snow.
 - a) Ensure that the heat pump is positioned at least 100 mm above the expected snow level.
 - b) In areas with heavy snowfall, install the unit where snow will not accumulate.

- c) If there is a risk of snow falling onto the heat pump, protect the heat pump by installing adequate snow protection.

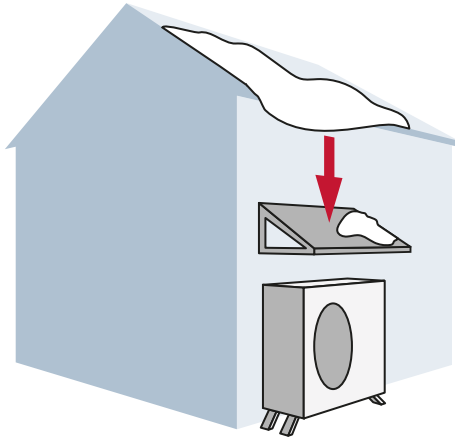

Additional components

Supplied components

The supplied components package contains the following items:

- Gas separator kit
- Two rubber mounts

Accessories

The product can be complemented with the following accessories.

ACCESSORY	PART NUMBER
Frost protection	1006963

3 COMPONENTS

Overview

The Quantum QA is an outdoor air heat pump unit that is installed with a Quantum QH hydronic unit.

The piping system is connected through connections that are on the back of the unit. The electrical system is connected to terminal blocks that are on the side of the unit.

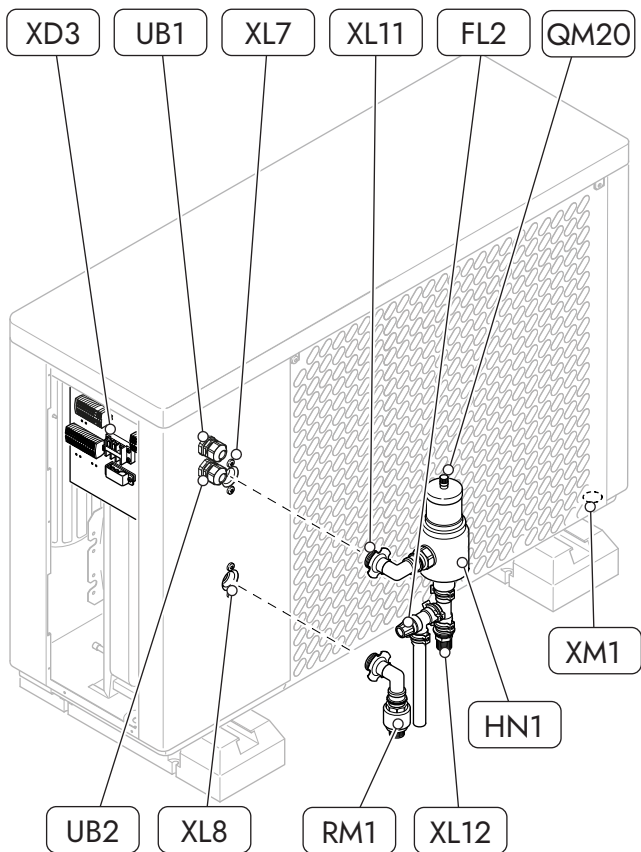

ID ¹	COMPONENT
FL2	Safety valve, distribution system
HN1	Gas separator
RM1	Check valve
UB1	Cable entry, power supply
UB2	Cable entry, communication
XD3	Junction box
XL7	Docking connection, outlet
XL8	Docking connection, inlet
XL11	Gas separator, inlet
XL12	Gas separator, outlet
XM1 ²	Drain outlet, condensation
QM20	Bleed valve, distribution system

¹ Component designations in accordance with IEC 81346.
² A drain connector accessory is required to connect the pipe/hose to the drain outlet.

Electrical box

ID ¹	COMPONENT
UB20	Cable retention, power supply
XD1	Terminal block, power supply
XD2	Terminal block, communication and sensors

¹ Component designations in accordance with IEC 81346.

QA-9

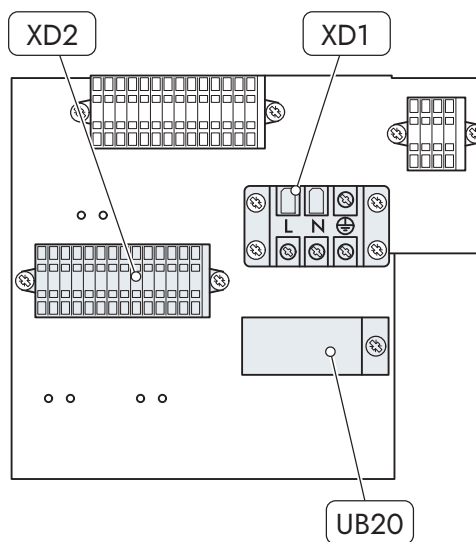

QA-15, 1-phase

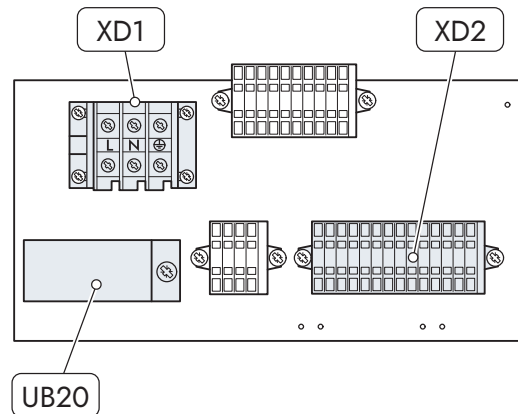

QA-15, 3-phase

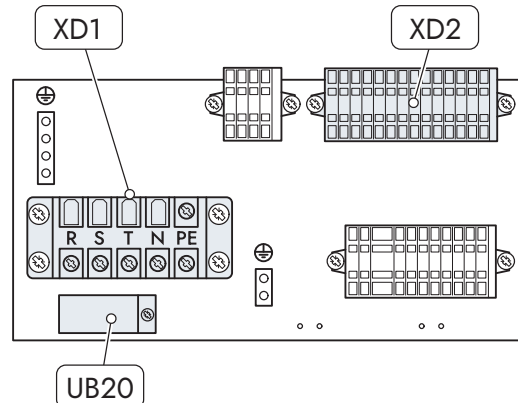

4 PIPE INSTALLATION

Pipe installation, general

NOTE

The pipe installations must be performed in accordance with applicable regulations.

CAUTION

Insulate all outdoor pipework to reduce heat loss and protect the pipes from freezing.

Pipe connections

Measurements and dimensions

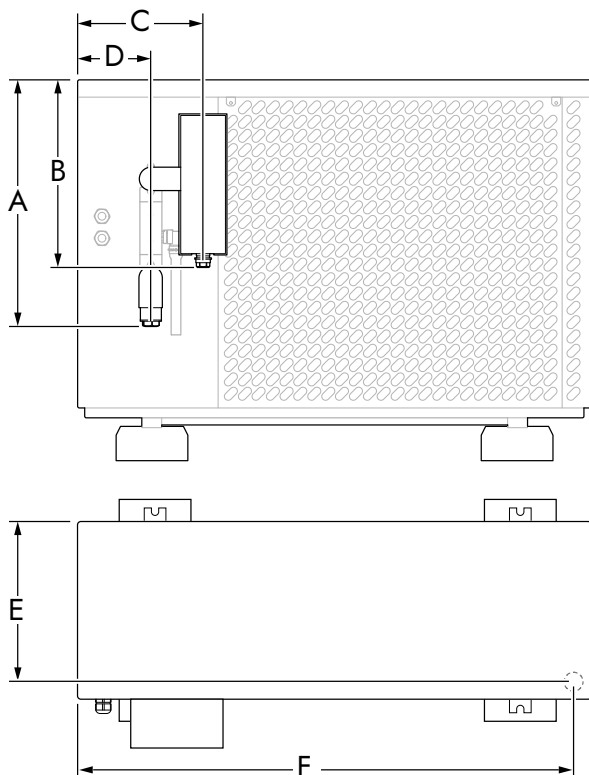

	QA-9	QA-15
A	575 mm	686 mm
B	445 mm	551 mm
C	283 mm	237 mm
D	165 mm	118 mm
E	353 mm	398 mm
F	1108 mm	1218 mm

Preparations

Assembly of gas separator kit

Assemble the gas separator kit before starting the pipe installation.

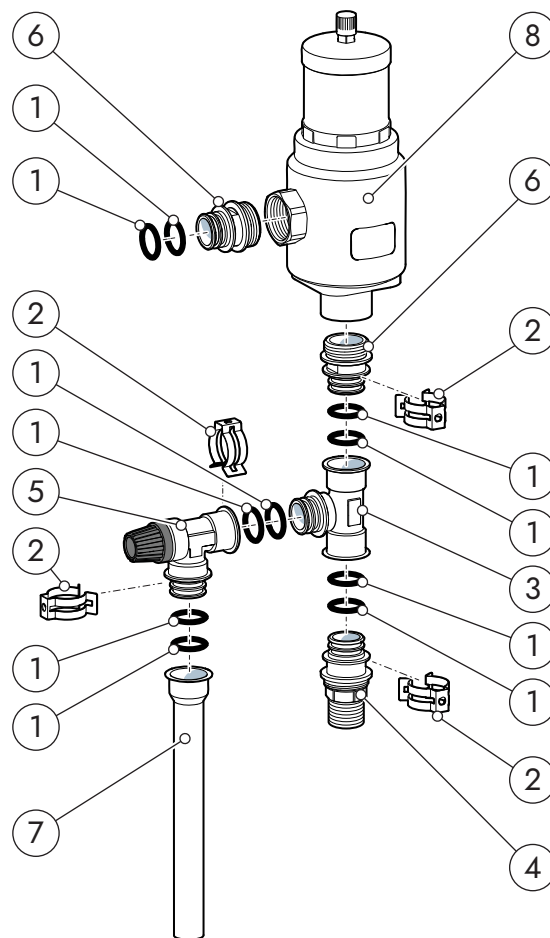

ID	COMPONENT
1	O-ring
2	Clip
3	T-connection
4	System connector
5	Safety valve
6	Adapter connection
7	Pipe
8	Gas separator

Vertical pipe routing

If the pipes are routed vertically, use the supplied extension for the gas separator housing to cover the pipes.

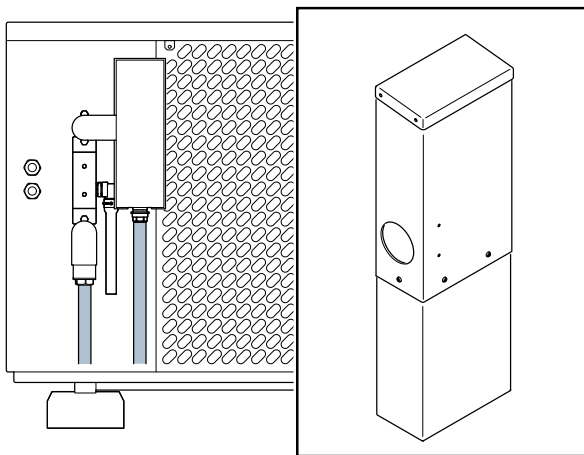

1. Place the extension inside the gas separator housing.
2. Fasten the extension with the supplied screws and washers.

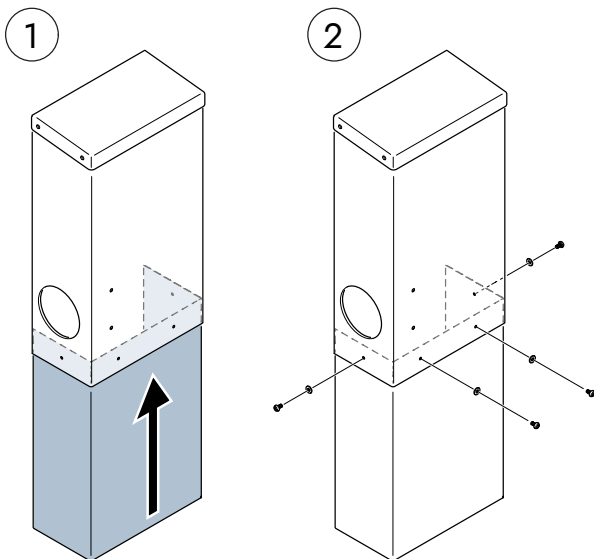

Horizontal pipe routing

If the pipes are routed horizontally, use the gas separator housing without the supplied extension to cover the pipes.

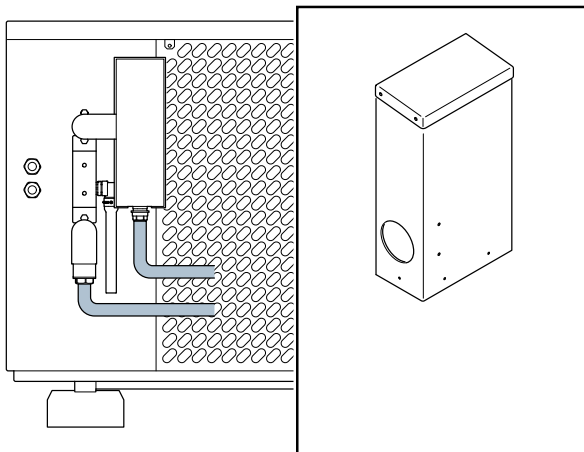

Recommended installation

Install the following components in the heating medium circuit to make future maintenance easier.

NOTE

The product is not equipped with shut-off valve and safety valve for the heating medium circuit.

- Install a shut-off valve on the heating medium supply line.
- Install a safety valve with an opening pressure of 3.5 bar on the heating medium supply line.
- Install a filter ball valve on the heating medium return line.

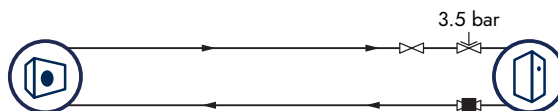

Installation

1. Install the supplied 90-degree couplings in the pipe connections at the back of the unit.

NOTE

Seal the threads of the couplings before installing them.

CAUTION

Do not remove the pre-fitted screws that are mounted above and below the pipe connections.

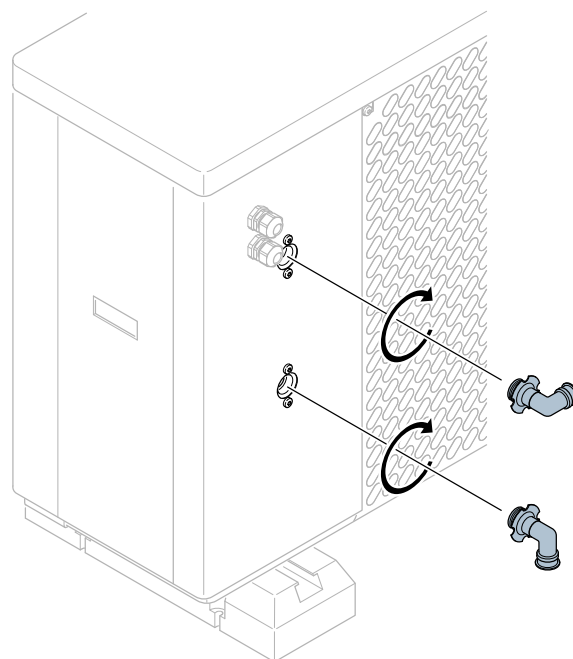

2. Ensure that the 90-degree couplings are mounted so that the coupling for the heating medium supply (XL7) points to the right and that the coupling for the heating medium return (XL8) points downwards.

 **NOTE**

Ensure that the distance between the back of the product and the top of the flanges of the couplings is 6 - 7.5 mm.

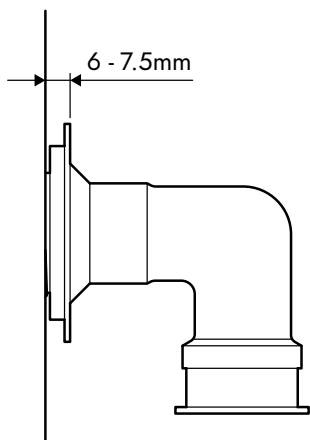
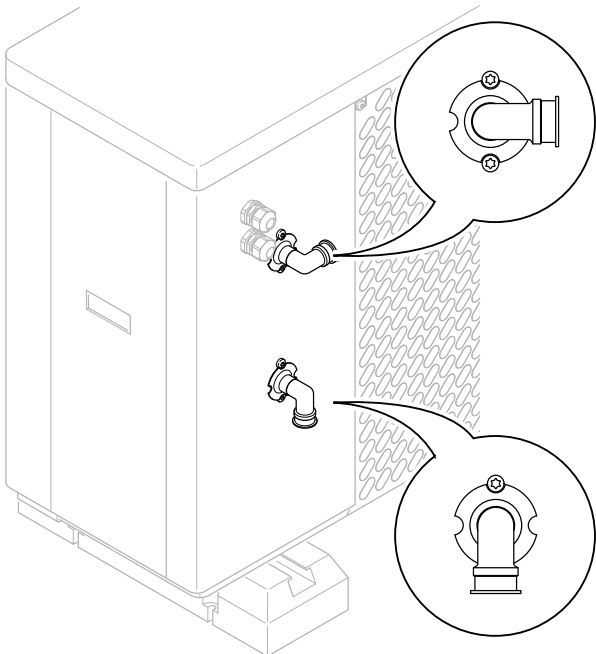

3. Remove the pre-fitted screws from the unit.

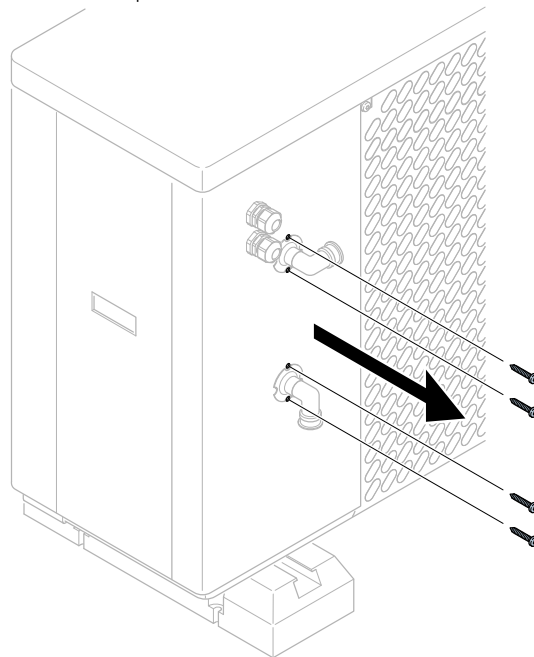

4. Fasten the 90-degree couplings and the supplied bracket with the supplied hexagonal screws.

 **CAUTION**

Fasten the top and bottom screws before fastening the bracket.

 **NOTE**

Place the bracket on top of the coupling flanges.

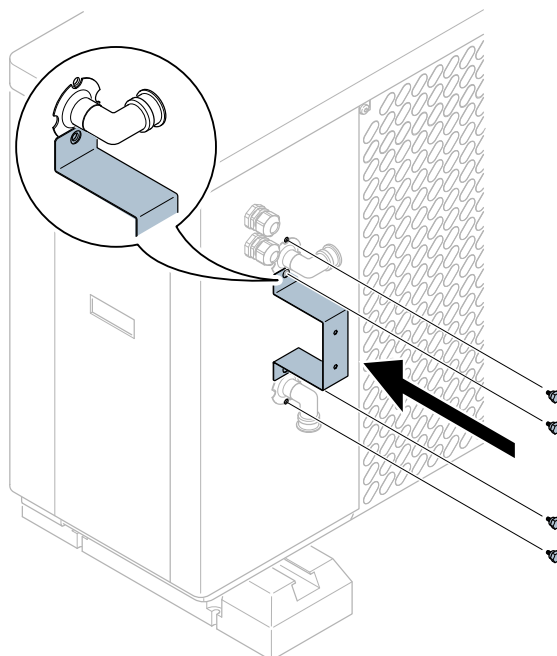

5. Install the gas separator (HN1) on the upper 90-degree coupling and the check valve (RM1) on the lower 90-degree coupling.

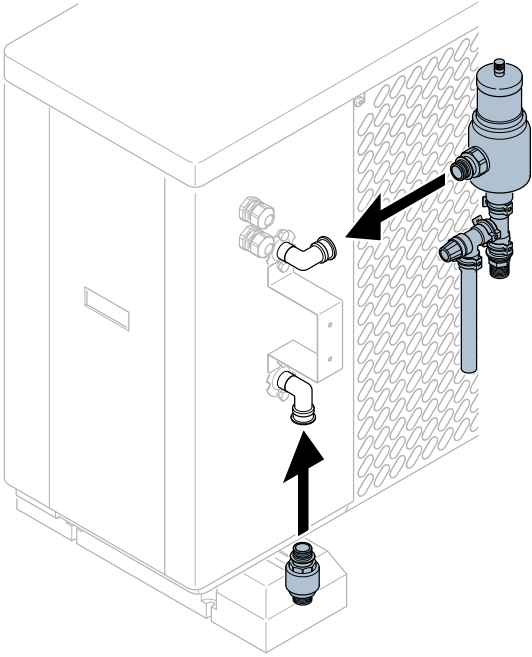

7. Attach condensation insulation along the pipes, from the back of the heat pump to the gas separator and over the check valve.

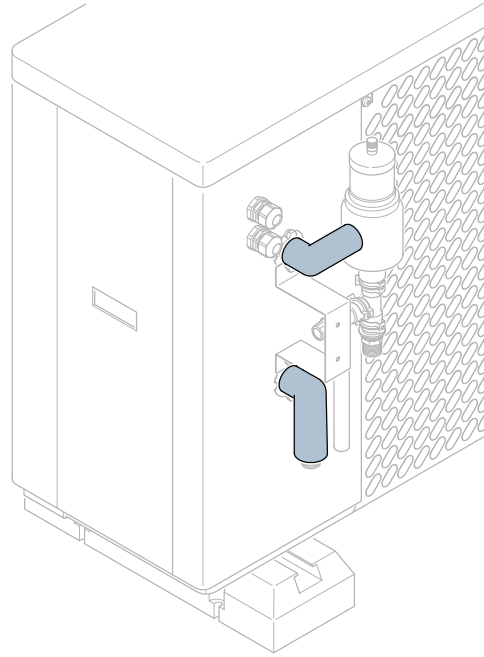

6. Mount the supplied click-fittings at the pipe transitions.

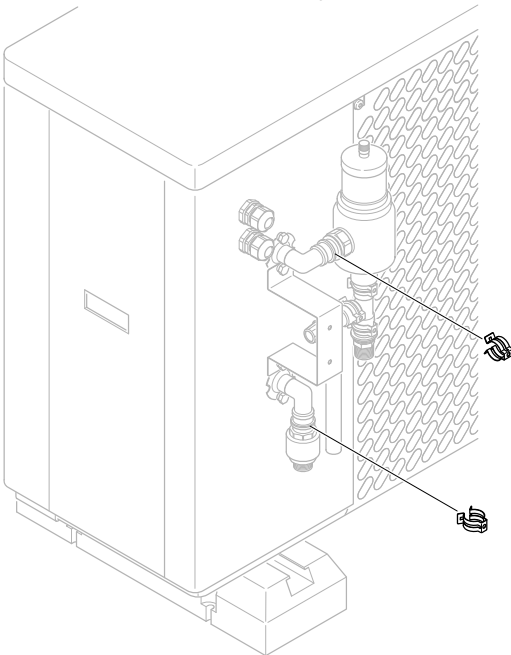

8. Install the rear and front insulation blocks around the gas separator.

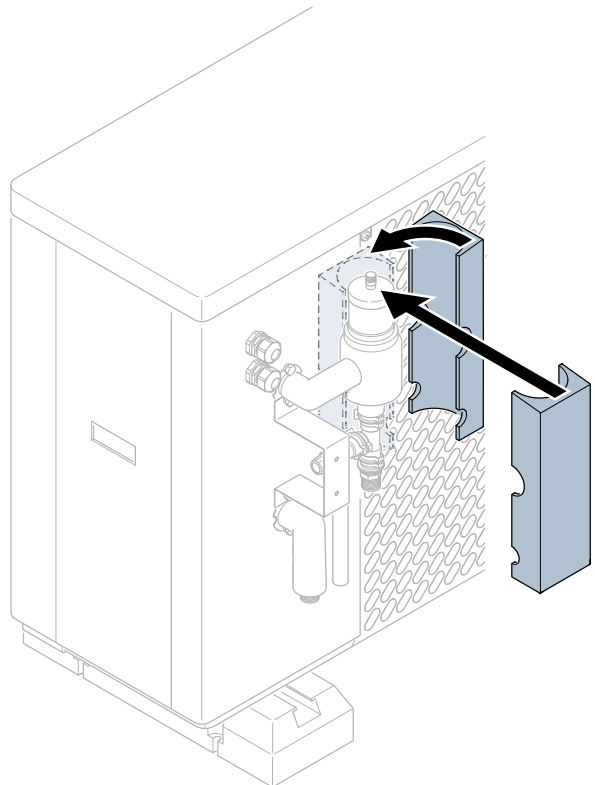

9. Install the pipes for the distribution system to the unit.
a) Connect the heating medium supply line to the gas separator outlet (XL12).

b) Connect the heating medium return line to the check valve connection (XL13).

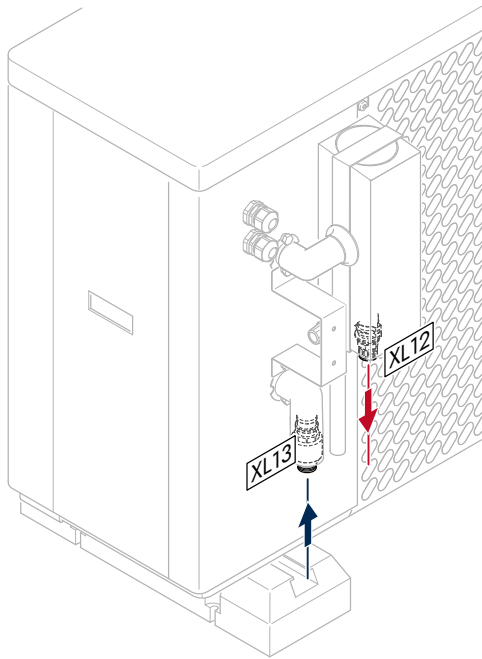

11. Install self-adhesive condensation insulation around gaps and pipe penetrations.

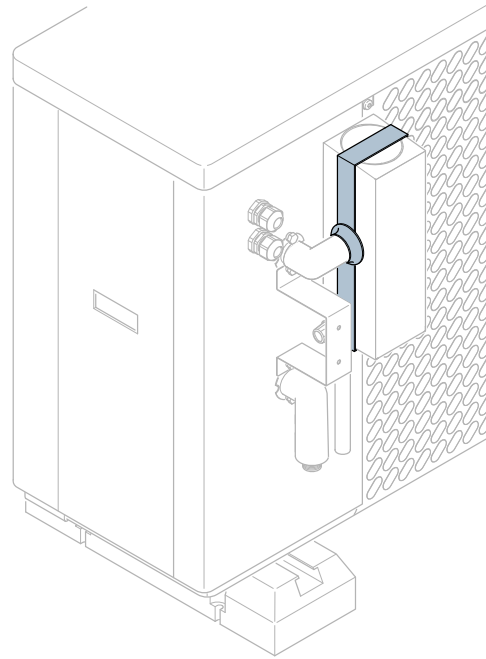

10. Mount the circular insulation lids at the top and bottom of the insulation blocks.

 **NOTE**

Mount the angled insulation lid at the top, and the open-end insulation lid at the bottom.

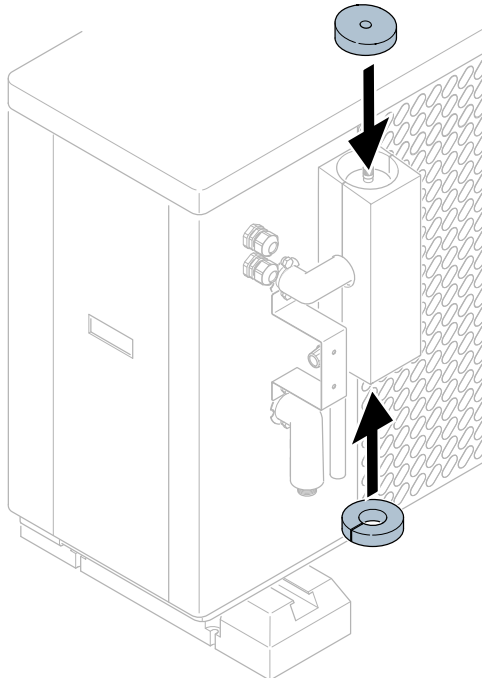

12. Install the gas separator casing on the bracket by using the supplied screws and washers.

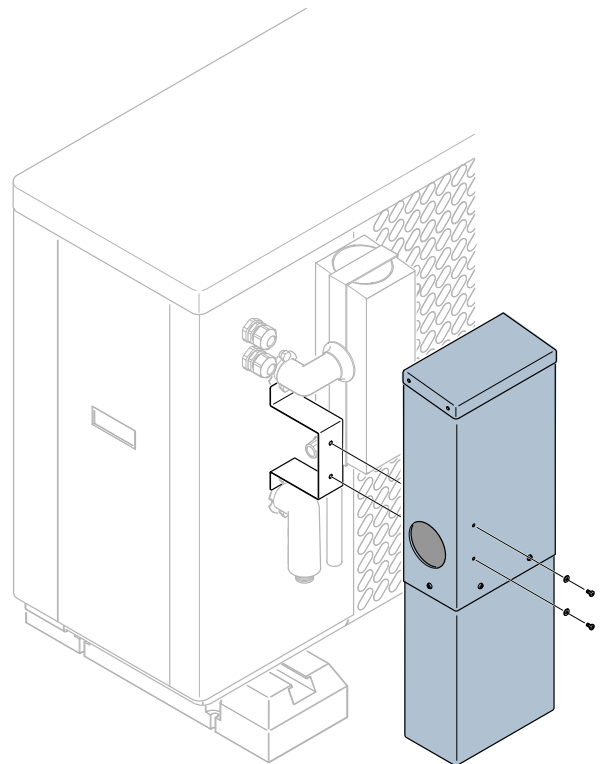

13. Attach the cover for the safety valve (FL2) to the gas separator casing.

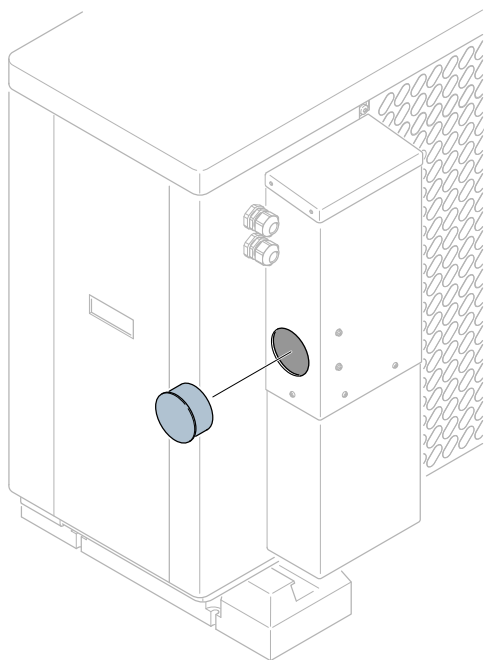

5 ELECTRICAL INSTALLATION

Electrical installation, general

⚠ WARNING

All electrical connections must be performed by a qualified electrician and in accordance with applicable regulations.

! CAUTION

Do not start the unit until it has been filled with water and all electrical connections have been checked. Premature start-up can cause damage to internal components.

- The unit must be disconnected before the house wiring is insulation tested.
- Power cables should be placed at least 200 mm from communication and sensor cables.
- The product must be installed with a separate residual current device (RCD) with a tripping current of 30 mA.

Cable channels

The heat pump has cable glands on the back of the unit.

ID CONNECTION TYPE

UB1	Power supply
UB2	Communication and external connections

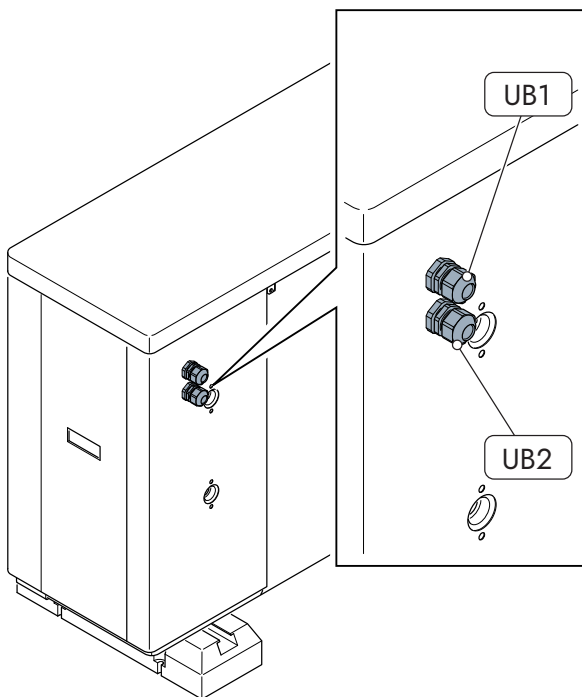

Access

Removal of side cover

This section describes how to access the electrical connections in the heat pump.

1. Hold the side cover in place.

2. Release the screws at the bottom of the side cover.

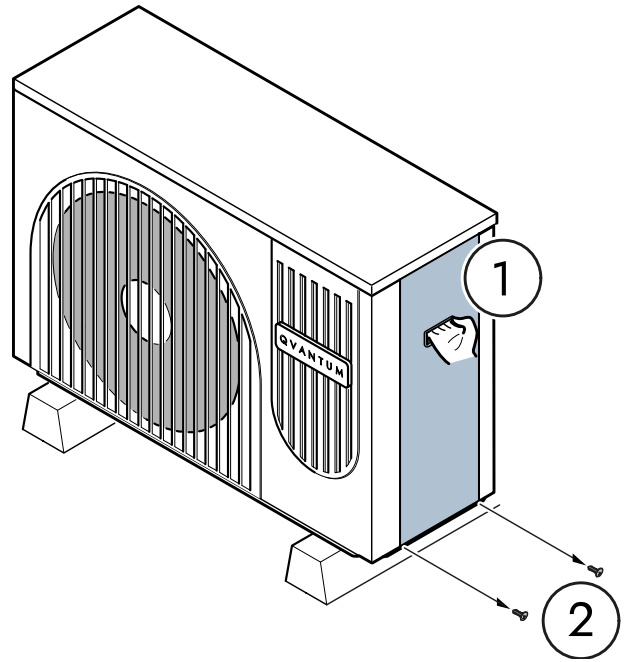

3. Slide the side cover downwards.
4. Remove the side cover from the heat pump.

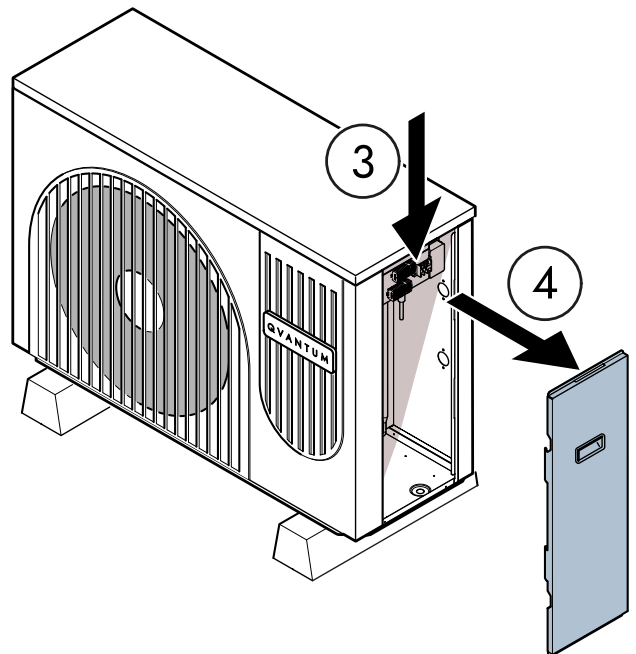

Removal of top cover

This section describes how to remove the top cover of the heat pump.

1. Remove the screws from the top of the heat pump.

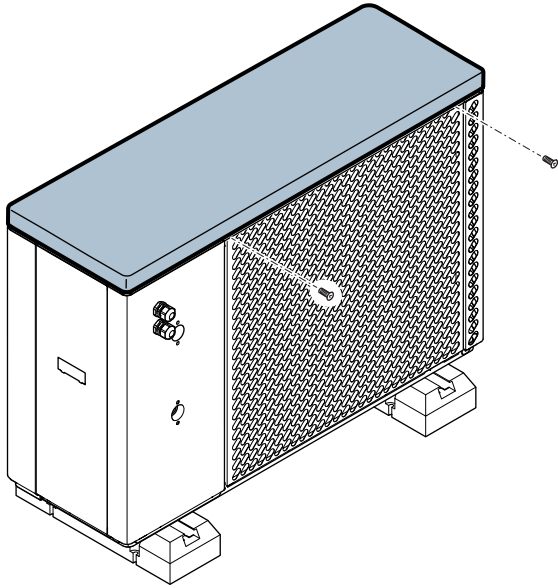

2. Remove the top cover of the heat pump.
 - a) Tilt the rear of the cover upwards.
 - b) Slide the cover forward.

NOTE

To allow the cover to come off the front clips, it must not be angled too high when disassembling.

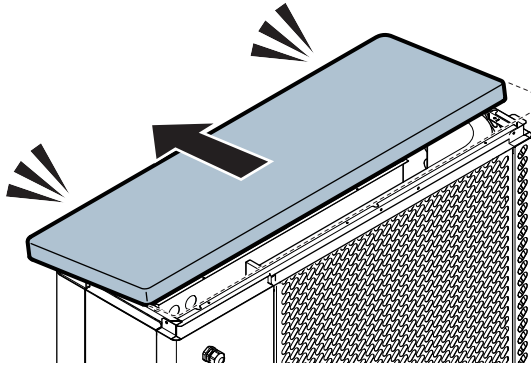
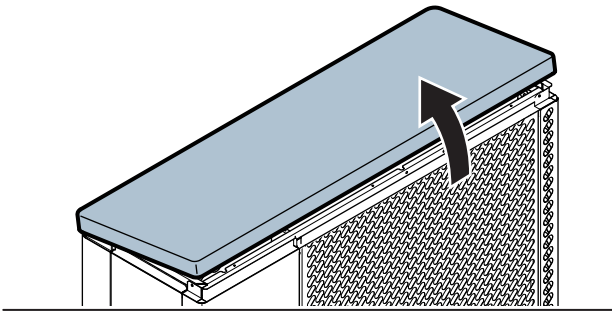

Electrical connections

Power connection

An isolator switch with a 3 mm minimum breaking distance must be used to install the unit. Size the minimum cable area in accordance with the fuse rating that is being used. Dimension the fuse size according to the following table.

MODEL	FUSE SIZE
QA-9	16 A (class C)
QA-15, 1x230 V	25 A (class C)
QA-15, 3x400 V	13 A (class C)

The power supply is connected to screw terminal block XD1.

NOTE

Secure the supply cable with the cable retention (UB20) on the junction box (XD3).

1x230 V

NOTE

If installed with a Quantum QH 3x400 V, it is recommended that the QA is connected to L3 in the main distribution board of the property.

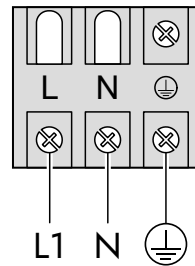

3x400 V

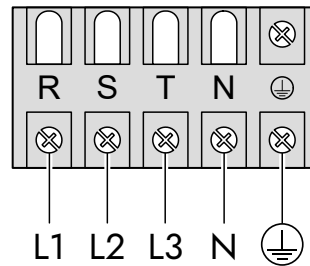

Hydronic unit

Connect the hydronic unit communication to spring load terminal blocks on XD2.

QA9

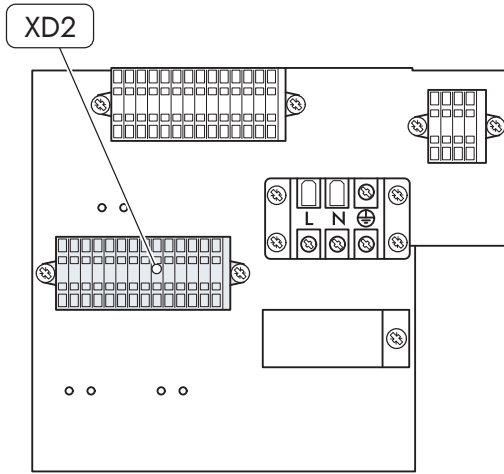

QA15-1

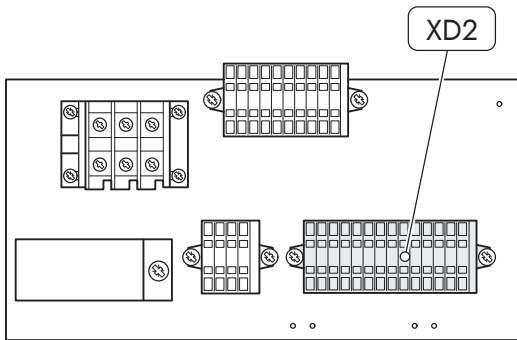

QA15-3

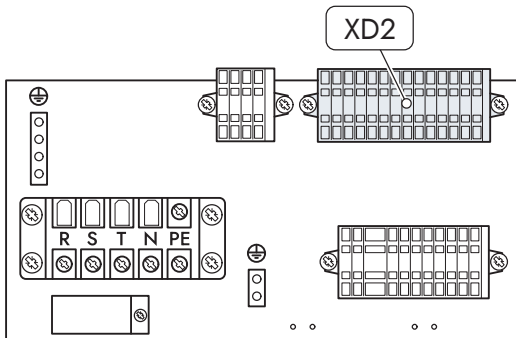

Connect the cables by inserting a screwdriver or similar at the top of the terminal block (1). When the spring in the terminal block is open, insert the cable (2).

The communication cable should be of type S/UTP, S/FTP or equivalent twisted-pair cable with a braided shield. The shield connects with grounding clips or a terminal block, depending on the hydronic unit version.

NOTE

Do not connect the shield to the heat pump unit.

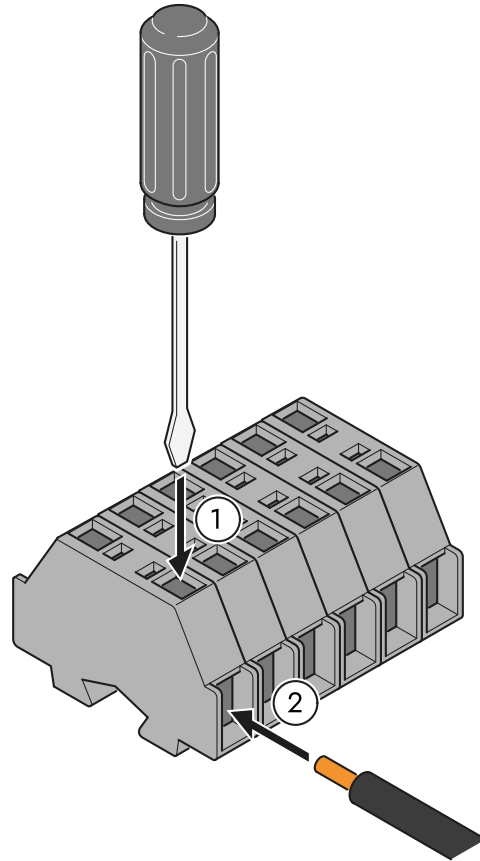

Hydronic unit with grounding clips

Attach the exposed shield to one of the grounding clips in the hydronic unit.

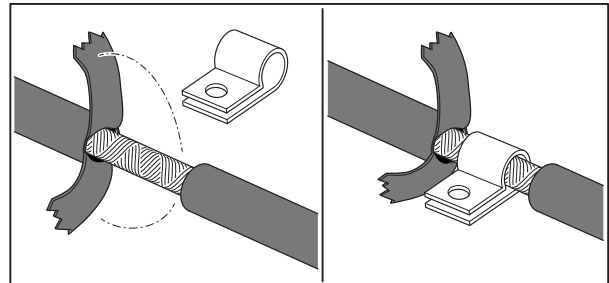

NOTE

Ensure that the shield has sufficient contact with the grounding clip.

Connect the communication wiring from the hydronic unit to XD2:12–14.

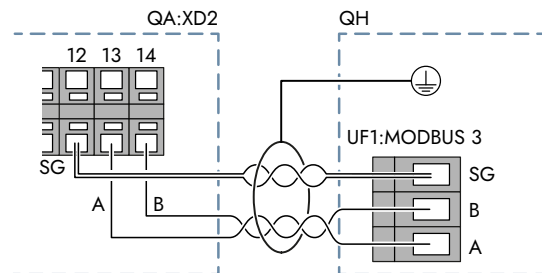

Hydronic unit without grounding clips

For hydronic units without grounding clips, connect the shield to XD2:PE.

NOTE

Do not let the shield touch the main board (UF1) or parts on the main board in the hydronic unit.

NOTE

The shield must not be exposed between the cable sheath and the connection point (XD2:PE).

Connect the communication wiring from the hydronic unit to XD2:12-14.

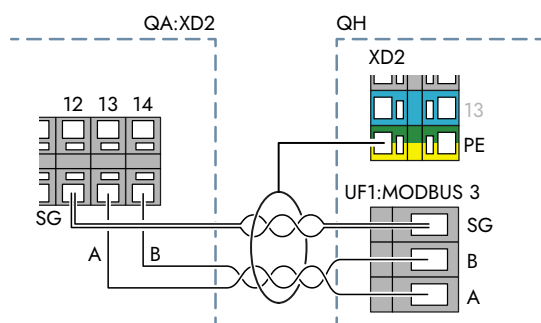

6 COMMISSIONING

Before first start-up

CAUTION

Before the first start-up, ensure that there is no frozen water in the system.

NOTE

Before the first start-up, ensure that there is water in the distribution system.

- Ensure that all pipe connections are correct and tightened.
- Ensure that the gas separator and the gas separator housing are mounted correctly.
- Ensure that the power supply to the heat pump is installed correctly.
- Ensure that the communication cable to the hydronic unit is installed correctly.
- Reassemble all covers.

First start-up

1. Turn on the isolator switch.
2. Verify that the heat pump is powered on.
3. Wait approx. 15 minutes before powering on the hydronic unit.

TIP

The compressor starts approximately one minute after a demand is detected by the controller.

4. If necessary, adjust affected settings through the display in the hydronic unit.

Compressor preheating

When the product is powered on, the compressor may enter a preheating mode before it can start. The preheating time depends on the outdoor air temperature. If the outdoor temperature is above +10 °C, preheating is not needed. If the outdoor temperature is below -25 °C, the compressor cannot start.

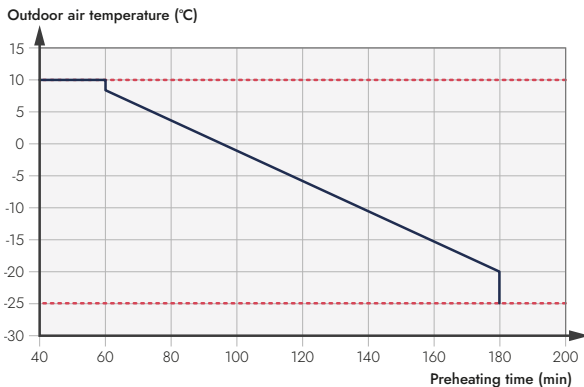

7 SERVICE

General

CAUTION

Maintenance and servicing must be performed by persons with sufficient knowledge about the task.

Maintenance

NOTE

The end user must be informed about necessary maintenance actions.

Regular checks

In order to prevent possible operational disturbances, regular checks of the heat pump must be carried out.

- Ensure that the unit is clean and free of debris.

NOTE

Clean the unit using hot water and a soft cloth. Do not use chemicals to clean the unit.

- Check that condensation water drain is not obstructed.
- Check the machine for uncontrolled ice formation.

Condenser draining

If an extended power failure occurs, it is necessary to drain water from the condenser to prevent freezing.

To safely drain the system proceed as follows:

1. Close the shut-off valve (A) on the heating medium supply line.
2. Close the filter ball valve (B) on the heating medium return line.

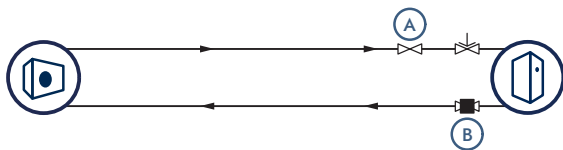

3. Open the safety valve (FL2) on the gas separator.
4. Release the pressure by opening the bleed valve (QM20) on the gas separator.

5. Disconnect the click-fitting and remove the check valve (RM1) on the heating medium return connection.

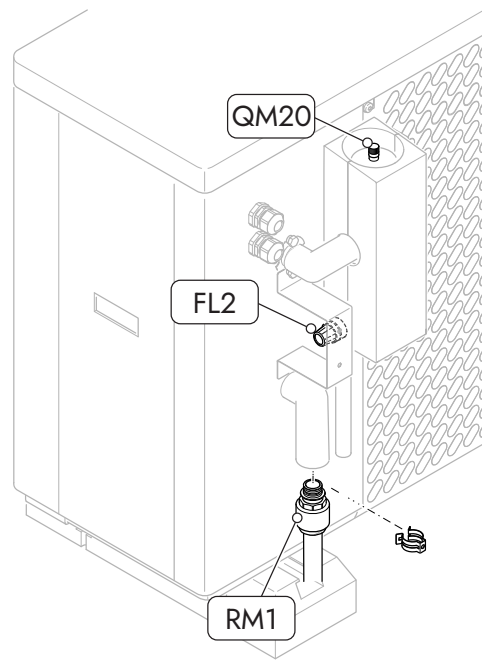

8 TROUBLESHOOTING

Before troubleshooting

If the system does not inform about an active fault, check the following components before troubleshooting:

- Power supply.
- Group and main fuses of the property.
- Residual current device (RCD).
- Internal fuses in the hydronic unit.
- Safety temperature limiter (*FQ10*) in the hydronic unit.
- That the air flow to the heat pump is not obstructed.

The heat pump does not start

An alarm is active

- Check the display unit of the hydronic unit for information about possible alarms.

No demand is active

- Heating or hot water production is not requested by the hydronic unit.

The compressor is blocked due to temperature limitations

- Ensure that the heat pump is not outside its operational range.

Compressor preheating is active

- Wait for the compressor preheating to finish.

Not enough time has passed since the previous compressor start

- Wait for approximately 30 minutes and see if the compressor starts.

No communication with hydronic unit

Incorrect power supply

- Verify the condition of the power supply for the heat pump unit.

Incorrect connection of communication

- Ensure that the communication cable is correctly installed.

Damaged communication cable

- Replace the communication cable.

Incorrect set-up in hydronic unit

- Ensure that the heat pump is correctly set up in the hydronic unit.

Insufficient hot water production

Increased hot water demand

- Wait until the target temperature for the hot water has been reached.

Air in the hydronic unit

- Purge the hydronic unit tank until only water comes out.

Incorrect hot water settings

- Check and, if necessary, change the hot water settings in the hydronic unit.

Obstructed filterball valve

- Turn off the power supply to the heat pump and clean the filterball valve that is connected to the heat pump inlet connection.

Low room temperature

Insufficient flow in distribution system

- Fully open several or all thermostats.

Incorrect room temperature settings

- Check, and if necessary, change the room temperature settings in the hydronic unit.

Air in distribution system

- Purge the distribution system.

Low compressor frequency

- Check the compressor frequency and make sure that the compressor parameters are adjusted properly.
 - a) If adjusting the compressor settings is not possible or insufficient, contact a service technician.

Fan is not running or is running too slowly

- Adjust the fan speed parameters.
 - a) If adjusting the fan speed settings is not possible or insufficient, contact a service technician.

Refrigerant leakage

- Check the exhaust temperature and the refrigerant pressure.
 - a) If a leakage is present, contact a service technician.

Obstructed filterball valve

- Turn off the power supply to the heat pump and clean the filterball valve that is connected to the heat pump inlet connection.

High room temperature

Incorrect room temperature settings

- Check, and if necessary, change the room temperature settings in the hydronic unit.

Frost build-up on evaporator

Insufficient air flow over the evaporator

- Check that the fan operates as intended.

Refrigerant amount issue

- Check the refrigerant pressure.
 - a) If a leakage is present, contact a service technician.

Too low compressor frequency

- Check the compressor frequency.
 - a) If adjusting the compressor settings is not possible or insufficient, contact a service technician.

Abnormal noise

Unfastened screws

- Ensure that all screws are properly fastened.

Fan blade or fan motor

- Ensure that the fan is functioning correctly and is firmly mounted.
- Ensure that the fan blades are free of ice.

Compressor

- Ensure that the compressor is functioning correctly and is firmly mounted.

Adjoining components

- Ensure that sound is not carried by components touching each other.

9 TECHNICAL SPECIFICATIONS

Sound levels

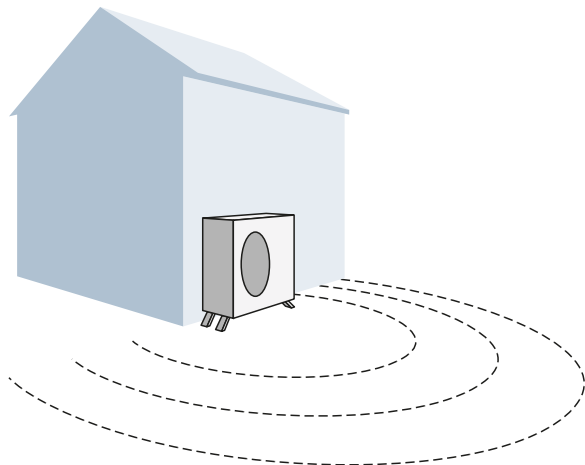

	QA9	QA15-1	QA15-3
--	-----	--------	--------

Sound power level, $L_w(A)_{EN12102}$

Sound pressure levels¹

	QA9	QA15-1	QA15-3
At 1 m	53	52	53
At 2 m	47	46	47
At 3 m	43	42	43
At 4 m	41	40	41
At 5 m	39	38	39
At 6 m	37	36	37
At 7 m	36	35	36
At 8 m	35	34	35
At 9 m	34	33	34
At 10 m	33	32	33

¹ Sound pressure levels are calculated using directivity factor Q=4.

Dimensions

QA-9

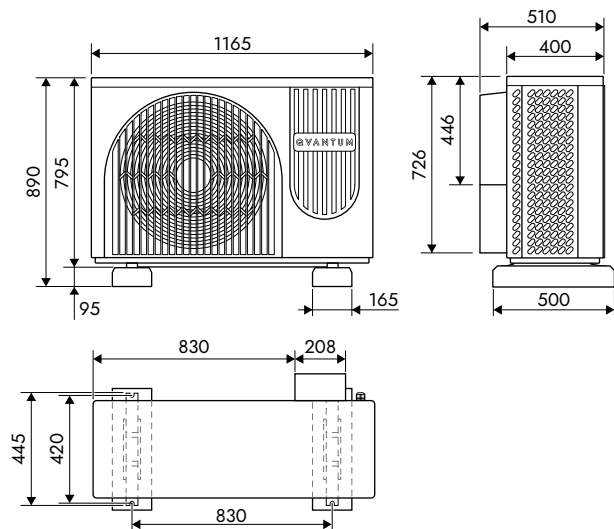

QA-15

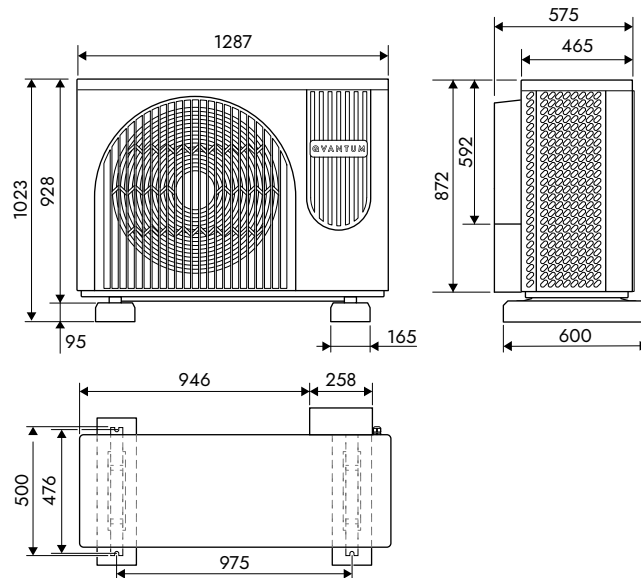

Operational data

Heating capacity

Heating capacity at supply line temperature 35 °C.

QA-9

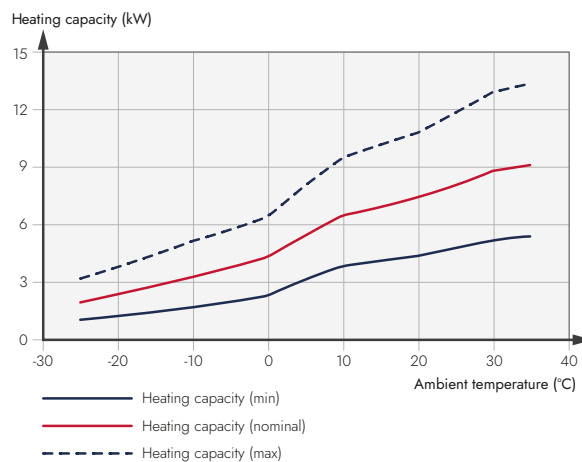

QA-15

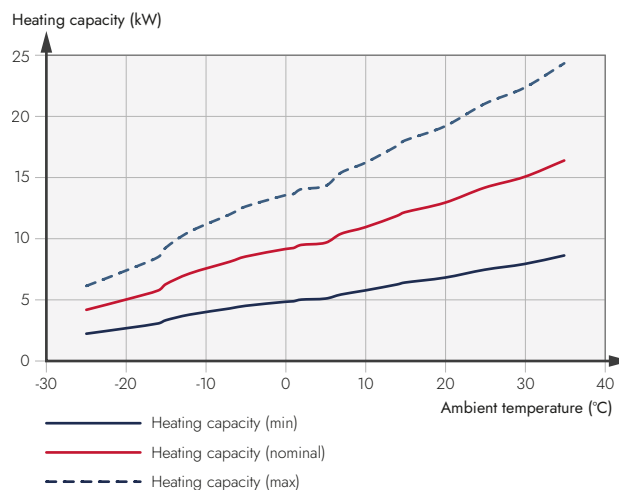

Pressure drop

QA-9

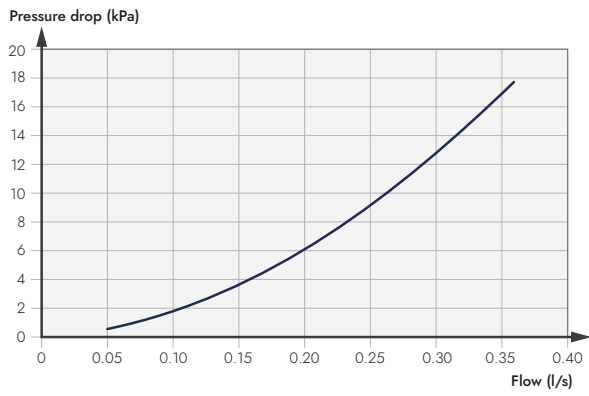

Operational range

Operational range during heating.

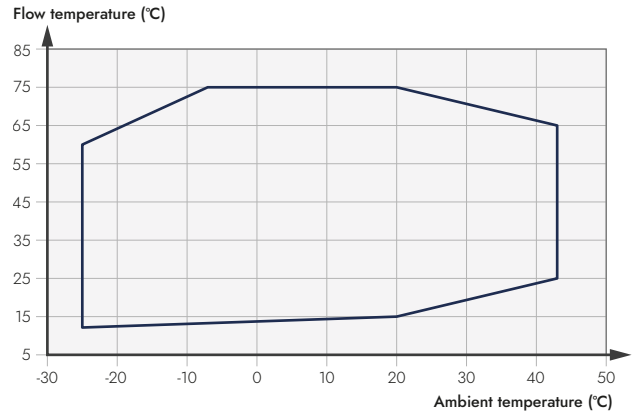

QA-15

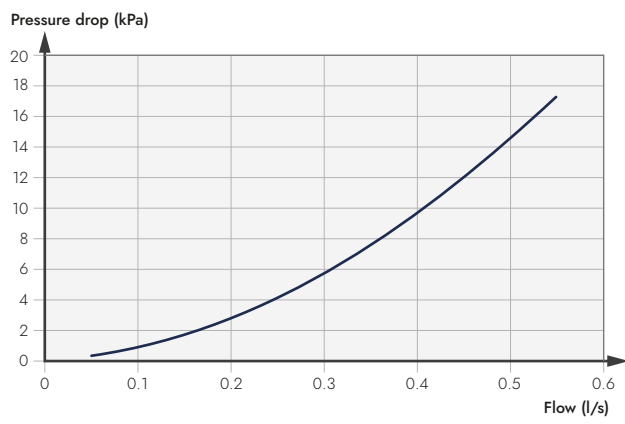

Technical data

MODEL		QA9	QA15-1	QA15-3
Energy efficiency, average climate				
The product's efficiency class room heating, average climate 35 / 55 °C		A+++ / A++	A+++ / A++	A+++ / A++
The system's efficiency class room heating, average climate 35 / 55 °C		A+++ / A++	A+++ / A+++	A+++ / A++
Output data (EN14825)				
Nominal heating output ($P_{designh}$), average climate 35 / 55 °C	kW	4.92 / 4.71	9.46 / 9.02	9.29 / 9.24
SCOP average climate, 35 °C / 55 °C		5.05 / 3.61	4.94 / 3.72	4.92 / 3.67
Heating capacity and COP (EN14511)				
Nominal heating capacity (A7/W35)	kW	6.38	9.99	8.38
Nominal heating capacity (A7/W55)	kW	5.58	9.52	9.6
Max. heating capacity (A-10/W55)	kW	4.72	9.15	8.69
COP (A7/W35)		4.94	4.71	3.96
COP (A7/W55)		3.04	3.0	3.04
Refrigerant circuit				
Type of refrigerant (GWP)		R290 (3)		
CO ₂ equivalent	kg	1.5	2.55	2.55
Refrigerant quantity	kg	0.5	0.85	0.85
Cut-out value pressostat LP	MPa/bar	0.8 / 8		
Cut-out value pressostat HP	MPa/bar	3.0 / 30		
Heating medium circuit				
Max pressure drop	kPa	40	20	20
Minimum flow	l/s	0.13	0.21	0.21
Nominal flow	l/s	0.28	0.47	0.47
Min. required flow during defrosting	l/s	0.2	0.33	0.33
Electrical data				
Rated voltage	V	230V 1N ~ 50Hz	230V 1N ~ 50Hz	400V 3N ~ 50Hz
Maximum power input	kW	3.0	5.3	5.3
Maximum current input	A	13.5	24.5	10.5
Recommended fuse	A	16	25	13
Recommended RCD type		B		
Enclosure class		IPX4		
Sound data				
Sound power level ($L_{W(A)}$) _{EN12102}	dB(A)	58	57	58
Sound power level, max ($L_{W(A)}$)	dB(A)	64	64	64
Fan data				
Fan motor type		DC motor		
Fan motor power input (min~max)	W	55~105	60~120	60~120
Fan speed	rpm	300~600	220~600	220~600
Connection dimensions				
Heating medium, external thread Ø		DN20	DN20	DN20
Recommended pipe dimension Ø	mm	22	28	28
Weight and dimensions				
Net weight	kg	98	140	140
W x D x H	mm	1165 x 400 x 795	1287 x 465 x 928	1287 x 465 x 928
Gross weight ¹	kg	140	189	189
W x D x H with packaging	mm	1400 x 500 x 1200	1400 x 500 x 1200	1400 x 500 x 1200
Misc				
Ambient temperature range, min-max	°C	-25~43		
Part no.		1003595	1003597	1003609

¹ The weight includes the packaging and the supplied components

Energy labelling

Data for energy efficiency of the product

SUPPLIER		QVANTUM	QVANTUM	QVANTUM
MODEL		QA9 + QH-175	QA15-1 + QH-175	QA15-3 + QH-175
Temperature application	°C	35 / 55	35 / 55	35 / 55
Declared load profile for water heating		XL	XL	XL
Seasonal space heating energy efficiency class, average climate		A+++ / A++	A+++ / A++	A+++ / A++
Water heating energy efficiency class, average climate		A	A	A
Rated heat output ($P_{designh}$), average climate	kW	4.9 / 4.7	9.5 / 9.0	9.3 / 9.2
Annual energy consumption space heating, average climate	kWh	2013 / 2701	3956 / 5014	3899 / 5200
Annual energy consumption water heating, average climate	kWh	1923	1928	2000
Seasonal space heating energy efficiency, average climate	%	199 / 141	195 / 146	194 / 144
Water heating energy efficiency, average climate	%	86	85.3	82.2
Sound power level L_{WA} indoors	dB	35	35	35
Sound power level L_{WA} outdoors	dB	58	57	58

Data for energy efficiency of the package

MODEL		QA9	QA15-1	QA15-3
CONTROLLER		QH-175	QH-175	QH-175
Temperature application	°C	35 / 55	35 / 55	35 / 55
Controller, class		VI	VI	VI
Controller, contribution to efficiency	%	4	4	4
Seasonal space heating energy efficiency of the package, average climate	%	203 / 145	199 / 150	198 / 148
Seasonal space heating energy efficiency class of the package, average climate		A+++ / A++	A+++ / A+++	A+++ / A++

Technical documentation

QA9

MODEL				QA9 + QH-175						
Type of heat pump				<input checked="" type="checkbox"/> Air-water <input type="checkbox"/> Exhaust-water <input type="checkbox"/> Brine-water <input type="checkbox"/> Water-water						
Low-temperature heat pump				<input type="checkbox"/> Yes <input checked="" type="checkbox"/> No						
Integrated immersion heater for additional heat				<input checked="" type="checkbox"/> Yes <input type="checkbox"/> No						
Heat pump combination heater				<input checked="" type="checkbox"/> Yes <input type="checkbox"/> No						
Climate				<input checked="" type="checkbox"/> Average <input type="checkbox"/> Cold <input type="checkbox"/> Warm						
Temperature application				<input checked="" type="checkbox"/> Medium (55°C) <input type="checkbox"/> Low (35°C)						
Applied standards				EN 14825, EN 16147						
Rated heat output		Prated	4.7	kW	Seasonal space heating energy efficiency		η_s	141	%	
Declared capacity for space heating at part load and at outdoor temperature T_j					Declared coefficient of performance for space heating at part load and at outdoor temperature T_j					
$T_j = -7\text{ °C}$		Pdh	4.2	kW	$T_j = -7\text{ °C}$		COPd	2.40	-	
$T_j = +2\text{ °C}$		Pdh	2.5	kW	$T_j = +2\text{ °C}$		COPd	3.49	-	
$T_j = +7\text{ °C}$		Pdh	2.4	kW	$T_j = +7\text{ °C}$		COPd	4.58	-	
$T_j = +12\text{ °C}$		Pdh	2.9	kW	$T_j = +12\text{ °C}$		COPd	5.96	-	
$T_j = \text{biv}$		Pdh	4.2	kW	$T_j = \text{biv}$		COPd	2.40	-	
$T_j = \text{TOL}$		Pdh	4.73	kW	$T_j = \text{TOL}$		COPd	2.05	-	
$T_j = -15\text{ °C}$ (if TOL < -20 °C)		Pdh		kW	$T_j = -15\text{ °C}$ (if TOL < -20 °C)		COPd		-	
Bivalent temperature		T_{biv}	-7	°C	Min. outdoor air temperature		TOL	-10	°C	
Cycling interval capacity		P_{cyc}		kW	Cycling interval efficiency		COPcyc		-	
Degradation coefficient		C_{dh}	0.98	-	Max supply temperature		WTOL		°C	
Power consumption in modes other than active mode					Additional heat					
Off mode		P_{OFF}	0.008	kW	Rated heat output		P_{sup}	0.0	kW	
Thermostat-off mode		P_{TO}	0.012	kW						
Standby mode		P_{SB}	0.008	kW	Type of energy input		Electric			
Crankcase heater mode		P_{CK}	0.008	kW						
Other items										
Capacity control		Variable			Rated air flow (air-water)			2400	m ³ /h	
Sound power level, indoors/outdoors		L_{WA}	35/58	dB	Nominal heating medium flow				m ³ /h	
Annual energy consumption		Q_{HE}	2701	kWh	Brine flow (brine-water or water-water heat pumps)				m ³ /h	
For heat pump combination heater										
Declared load profile for water heating				XL		Water heating energy efficiency		η_{wh}	86	%
Daily energy consumption		Q_{elec}	7.77	kWh	Daily fuel consumption		Q_{fuel}		kWh	
Annual energy consumption		AEC	1923	kWh	Annual fuel consumption		AFC		GJ	
Contact information		Qvantum Energi AB - Ji-te gatan 7 - 265 38 Åstorp - Sweden								

QA15-1

MODEL				QA15-1 + QH-175					
Type of heat pump				<input checked="" type="checkbox"/> Air-water <input type="checkbox"/> Exhaust-water <input type="checkbox"/> Brine-water <input type="checkbox"/> Water-water					
Low-temperature heat pump				<input type="checkbox"/> Yes <input checked="" type="checkbox"/> No					
Integrated immersion heater for additional heat				<input checked="" type="checkbox"/> Yes <input type="checkbox"/> No					
Heat pump combination heater				<input checked="" type="checkbox"/> Yes <input type="checkbox"/> No					
Climate				<input checked="" type="checkbox"/> Average <input type="checkbox"/> Cold <input type="checkbox"/> Warm					
Temperature application				<input checked="" type="checkbox"/> Medium (55°C) <input type="checkbox"/> Low (35°C)					
Applied standards				EN 14825, EN 16147					
Rated heat output		Prated	9.0	kW	Seasonal space heating energy efficiency		η_s	146	%
Declared capacity for space heating at part load and at outdoor temperature T_j					Declared coefficient of performance for space heating at part load and at outdoor temperature T_j				
$T_j = -7\text{ °C}$		Pdh	8.1	kW	$T_j = -7\text{ °C}$		COPd	2.24	-
$T_j = +2\text{ °C}$		Pdh	4.9	kW	$T_j = +2\text{ °C}$		COPd	3.63	-
$T_j = +7\text{ °C}$		Pdh	4.5	kW	$T_j = +7\text{ °C}$		COPd	4.90	-
$T_j = +12\text{ °C}$		Pdh	5.3	kW	$T_j = +12\text{ °C}$		COPd	6.46	-
$T_j = \text{biv}$		Pdh	8.1	kW	$T_j = \text{biv}$		COPd	2.24	-
$T_j = \text{TOL}$		Pdh	9.15	kW	$T_j = \text{TOL}$		COPd	2.04	-
$T_j = -15\text{ °C}$ (if TOL < -20 °C)		Pdh		kW	$T_j = -15\text{ °C}$ (if TOL < -20 °C)		COPd		-
Bivalent temperature		T_{biv}	-7	°C	Min. outdoor air temperature		TOL	-10	°C
Cycling interval capacity		P_{cyc}		kW	Cycling interval efficiency		COPcyc		-
Degradation coefficient		C_{dh}	0.98	-	Max supply temperature		WTOL		°C
Power consumption in modes other than active mode					Additional heat				
Off mode		P_{OFF}	0.008	kW	Rated heat output		P_{sup}	0.0	kW
Thermostat-off mode		P_{TO}	0.016	kW					
Standby mode		P_{SB}	0.008	kW	Type of energy input		Electric		
Crankcase heater mode		P_{CK}	0.008	kW					
Other items									
Capacity control		Variable			Rated air flow (air-water)			4000	m ³ /h
Sound power level, indoors/outdoors		L_{WA}	35/57	dB	Nominal heating medium flow				m ³ /h
Annual energy consumption		Q_{HE}	5014	kWh	Brine flow (brine-water or water-water heat pumps)				m ³ /h
For heat pump combination heater									
Declared load profile for water heating		XL			Water heating energy efficiency		η_{wh}	85.3	%
Daily energy consumption		Q_{elec}	7.60	kWh	Daily fuel consumption		Q_{fuel}		kWh
Annual energy consumption		AEC	1928	kWh	Annual fuel consumption		AFC		GJ
Contact information		Qvantum Energi AB - Ji-te gatan 7 - 265 38 Åstorp - Sweden							

QA15-3

MODEL		QA15-3 + QH-175					
Type of heat pump	<input checked="" type="checkbox"/> Air-water <input type="checkbox"/> Exhaust-water <input type="checkbox"/> Brine-water <input type="checkbox"/> Water-water						
Low-temperature heat pump	<input type="checkbox"/> Yes <input checked="" type="checkbox"/> No						
Integrated immersion heater for additional heat	<input checked="" type="checkbox"/> Yes <input type="checkbox"/> No						
Heat pump combination heater	<input checked="" type="checkbox"/> Yes <input type="checkbox"/> No						
Climate	<input checked="" type="checkbox"/> Average <input type="checkbox"/> Cold <input type="checkbox"/> Warm						
Temperature application	<input checked="" type="checkbox"/> Medium (55°C) <input type="checkbox"/> Low (35°C)						
Applied standards	EN 14825, EN 16147						
Rated heat output	Prated	9.2	kW	Seasonal space heating energy efficiency	η_s	144	%
Declared capacity for space heating at part load and at outdoor temperature T_j				Declared coefficient of performance for space heating at part load and at outdoor temperature T_j			
$T_j = -7\text{ °C}$	Pdh	8.0	kW	$T_j = -7\text{ °C}$	COPd	2.21	-
$T_j = +2\text{ °C}$	Pdh	4.9	kW	$T_j = +2\text{ °C}$	COPd	3.64	-
$T_j = +7\text{ °C}$	Pdh	4.5	kW	$T_j = +7\text{ °C}$	COPd	4.66	-
$T_j = +12\text{ °C}$	Pdh	5.2	kW	$T_j = +12\text{ °C}$	COPd	6.38	-
$T_j = \text{biv}$	Pdh	8.0	kW	$T_j = \text{biv}$	COPd	2.21	-
$T_j = \text{TOL}$	Pdh	8.7	kW	$T_j = \text{TOL}$	COPd	1.94	-
$T_j = -15\text{ °C}$ (if TOL < -20 °C)	Pdh		kW	$T_j = -15\text{ °C}$ (if TOL < -20 °C)	COPd		-
Bivalent temperature	T_{biv}	-7	°C	Min. outdoor air temperature	TOL	-10	°C
Cycling interval capacity	P_{cyc}		kW	Cycling interval efficiency	COPcyc		-
Degradation coefficient	C_{dh}	0.99	-	Max supply temperature	WTOL		°C
Power consumption in modes other than active mode				Additional heat			
Off mode	P_{OFF}	0.01	kW	Rated heat output	P_{sup}	0.54	kW
Thermostat-off mode	P_{TO}	0.01	kW				
Standby mode	P_{SB}	0.01	kW	Type of energy input	Electric		
Crankcase heater mode	P_{CK}	0.01	kW				
Other items							
Capacity control	Variable			Rated air flow (air-water)		4000	m ³ /h
Sound power level, indoors/outdoors	L_{WA}	35/58	dB	Nominal heating medium flow			m ³ /h
Annual energy consumption	Q_{HE}	5200	kWh	Brine flow (brine-water or water-water heat pumps)			m ³ /h
For heat pump combination heater							
Declared load profile for water heating	XL			Water heating energy efficiency	η_{wh}	82.2	%
Daily energy consumption	Q_{elec}	7.6	kWh	Daily fuel consumption	Q_{fuel}		kWh
Annual energy consumption	AEC	2000	kWh	Annual fuel consumption	AFC		GJ
Contact information	Qvantum Energi AB - Ji-te gatan 7 - 265 38 Åstorp - Sweden						

Index

A

Accessories [7](#)

B

Before installing
Transport [6](#)

C

Commissioning [19](#)

E

Electrical connections [16](#)
Power connection [16](#)
Electrical installation [15](#)
Hydronic unit [17](#)
Environmental information [4](#)

I

Important information
Environmental information [4](#)
Product labels [4](#)
Safety [3](#)

P

Pipe connections [9](#)
Pipe installation
Installation [10](#)
Preparations [9](#)

S

Supplied components [7](#)

T

Technical specifications
Dimensions [23](#)
Energy labelling [26](#)
Sound levels [23](#)
Technical data [25](#)
Transport [6](#)
Troubleshooting [21](#)
Before troubleshooting [21](#)



This Commissioning Checklist is to be completed in full by the competent person who commissioned the heat pump and associated equipment as a means of demonstrating compliance with the appropriate Building Regulations and then handed to the customer to keep for future reference.

Failure to install and commission this equipment to the manufacturer's instructions may invalidate the warranty but does not affect statutory rights.

Customer name:	Tele phone number:
Address:	
Heat Pump Make and Model	
Heat Pump Serial Number	
Commissioned by (PRINT NAME):	Certified Operative Reg No. (1)
Company name:	Tele phone number:
Company address:	
	Commissioning date:
Building Regulations Notification Number (if applicable) (2).	

CONTROLS - SYSTEM AND HEAT PUMP (tick the appropriate boxes)			
Time and temperature control to heating	Room thermostat and programmer/timer Load/weather	Programmable Roomstat Optimum start controls	
Time and temperature control to hot water	Cylinder thermostat and programmer/timer	Combined with Heat pump main controls	
Heating Zone Valves (including underfloor loops)	Fitted	Not required	
Hot water zone valves	Fitted	Not required	
Thermostatic radiator valves	Fitted	Not required	
Heat Pump Safety Interlock (3)	Built In	Provided	
Outdoor Sensor	Fitted	Not required	
Automatic bypass to system	Fitted	Not required	
Buffer Vessel Fitted	Yes	No	If YES Volume: Litres

ALL SYSTEMS			
The heating system has been fitted and pressure tested			Yes
Expansion Vessel for heating is sized, fitted & charged in accordance with manufacturer's instructions			Yes
The heat pump is fitted on a solid/stable surface capable of taking its weight			Yes
The system has been flushed and cleaned in accordance with BS7593 and heat pump manufacturer's instructions			Yes
What system cleaner was used?			
What inhibitor was used?		Quantity	litres
Is the system adequately frost protected?			Yes

OUTDOOR UNIT			
Are all external pipeworks insulated?			Yes
Is the fan free from obstacles and operational?			Yes
Has suitable consideration been made for waste water discharge?			Yes

CENTRAL HEATING MODE			
Heating Flow Temperature	°C	Heating Return Temperature	°C

DOMESTIC HOT WATER MODE Measure and Record:			
Is the heat pump connected to a hot water cylinder?	Unvented	Vented	Thermal Store Not Connected
Hot water has been checked at all outlets	Yes	Have Thermostatic Blending Valves been fitted?	Yes Not required

ADDITIONAL SYSTEM INFORMATON					
Additional heat sources connected:	Gas Boiler	Oil Boiler	Electric Heater	Solar Thermal	Other:

ALL INSTALLATIONS			
The heating, hot water and ventilation systems complies with the appropriate Building Regulations			Yes
All electrical work complies with the appropriate Regulations			Yes
The heat pump and associated products have been installed and commissioned in accordance with the manufacturer's instructions			Yes
The operation of the heat pump and system controls have been demonstrated to the customer			Yes
The manufacturer's literature, including Benchmark Checklist and Service Record, has been explained and left with the customer			Yes
Distance to Neighboring property (m)			
Commissioning Engineer's Signature			
Customer's Signature			
(To confirm satisfactory demonstration and receipt of manufacturer's literature)			

Notes: (1) Installers should be members of an appropriate Competent Persons Scheme. (2) All installations in England and Wales must be notified to Local Area Building Control (LABC) either directly or through a Competent Persons Scheme. A Building Regulations Compliance Certificate will then be issued to the customer. (3) May be required for systems covered By G3 Regulations.



SERVICE RECORD

It is recommended that your heating system is serviced regularly and that the appropriate Service Interval Record is completed.

Service Provider

Before completing the appropriate Service Interval Record below, please ensure you have carried out the service as described in the manufacturer's Instructions. Always use the manufacturer's specified spare part when replacing controls.

SERVICE 01		Date:	SERVICE 02		Date:
Engineer name:		Engineer name:			
Company name:		Company name:			
Tele phone No:		Tele phone No:			
Comments:		Comments:			
Signature		Signature			
SERVICE 03		Date:	SERVICE 04		Date:
Engineer name:		Engineer name:			
Company name:		Company name:			
Tele phone No:		Tele phone No:			
Comments:		Comments:			
Signature		Signature			
SERVICE 05		Date:	SERVICE 06		Date:
Engineer name:		Engineer name:			
Company name:		Company name:			
Tele phone No:		Tele phone No:			
Comments:		Comments:			
Signature		Signature			
SERVICE 07		Date:	SERVICE 08		Date:
Engineer name:		Engineer name:			
Company name:		Company name:			
Tele phone No:		Tele phone No:			
Comments:		Comments:			
Signature		Signature			
SERVICE 09		Date:	SERVICE 10		Date:
Engineer name:		Engineer name:			
Company name:		Company name:			
Tele phone No:		Tele phone No:			
Comments:		Comments:			
Signature		Signature			

QCH EN 2601-A



1013758

This publication presents information that was valid at the time of publishing.
Quantum reserves the right to make changes without prior notification.
Subject to possible printing errors.
©2026 Quantum Energi AB

HEAT PUMPS FOR SUSTAINABLE CITIES

WE CHANGE THE WAY THE CITIES OF EUROPE ARE HEATED

Quantum, founded in Sweden in 1993, develops high-quality heat pumps for individual buildings and innovative heat pump-based solutions for densely populated areas to enable everybody to benefit from emission free heating and cooling. The company has deep knowledge in both heat pump technology and energy systems engineering and works in close collaboration with engineering consultants, installers, project developers and utilities.

Quantum Energi AB

Ji-te gatan 7, 265 38 Åstorp – Sweden | quantum.com



Q V A N T U M