

# **Quantum QS**

---

## Supply air module



## Installation handbook

QIH EN 2540-A  
1012559

# CONTENTS

<b>1 Important information.....</b>	<b>3</b>	<b>11 Technical specifications.....</b>	<b>21</b>
General.....	3	Dimensions.....	21
Safety.....	3	Technical data.....	21
Symbols.....	3		
Product labels.....	3	<b>Index.....</b>	<b>22</b>
Serial number and QR code.....	3		
Product registration.....	3		
Environmental information.....	4		
<b>2 Before installing.....</b>	<b>5</b>		
Transport.....	5		
Installation area.....	5		
Additional components.....	5		
Front cover removal.....	5		
<b>3 Components.....</b>	<b>7</b>		
Overview.....	7		
<b>4 Wall mount installation.....</b>	<b>8</b>		
Positioning.....	8		
Installation.....	8		
<b>5 Pipe installation.....</b>	<b>11</b>		
Pipe installation, general.....	11		
Pipe connections.....	11		
Capacity declaration.....	13		
<b>6 Ventilation installation.....</b>	<b>15</b>		
Ventilation installation, general.....	15		
Ventilation connections.....	15		
Measurements and dimensions.....	16		
Ventilation flow and adjustments.....	16		
Ventilation capacity.....	16		
<b>7 Electrical installation.....</b>	<b>17</b>		
Electrical installation, general.....	17		
Power supply.....	17		
<b>8 Commissioning.....</b>	<b>18</b>		
Quantum app.....	18		
Preparations.....	18		
Filling.....	18		
Venting.....	18		
First start-up.....	18		
<b>9 Service.....</b>	<b>19</b>		
General.....	19		
Maintenance.....	19		
<b>10 Troubleshooting.....</b>	<b>20</b>		
Before troubleshooting.....	20		
Insufficient ventilation.....	20		
Abnormal ventilation noise.....	20		
Low supply air temperature.....	20		

# 1 IMPORTANT INFORMATION

## General

### **WARNING**

Read this manual before starting the unit for the first time.

It is the owner of the product that is responsible for the system. If you suspect that the product is defective, contact your dealer.

## Safety

This appliance can be used by children from 8 years and above and people with reduced physical, sensory or mental capabilities or lack of experience and knowledge if they have been given supervision or instruction concerning the use of the appliance in a safe way and understand the hazards involved. Children must not play with the appliance. Cleaning and maintenance must not be performed by children unless they are older than 8 and supervised.

The manual must be available for people who install, support or use the product.

Companies and service technicians who install or perform maintenance work on the product must be authorized and have the necessary certificates and licenses.

The work must follow applicable rules and regulations. Ensure that the work is carried out in a professional manner.

When powering up the product, there must be no frozen water in the system.

Wiring and electrical installation must be performed in compliance with national regulations.

It must be possible to safely disconnect the electrical power supply to the product.

## Symbols

The manual contains the following symbols

### **WARNING**

This symbol describes information that is of great danger to people or equipment.

### **CAUTION**

This symbol describes information that could cause danger to people or equipment.

### **NOTE**

This symbol describes information that is crucial when installing or servicing the product.

### **TIP**

This symbol describes information that can be helpful when installing or servicing the product.

## Product labels

These labels are found on the product.



CE marking indicates that a product has been assessed by the manufacturer and deemed to meet EU safety, health and environmental protection requirements.

IP21

Protection classification against water and dust in the electrical enclosure.

## Serial number and QR code

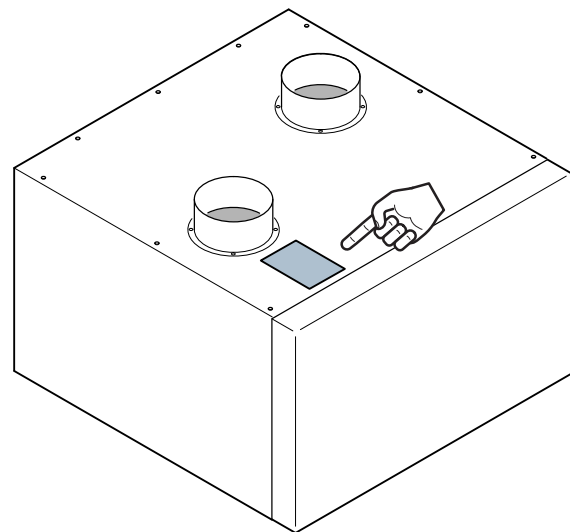

## Product registration

The product must be registered for the warranty to take effect.

The product can be registered no more than 12 months after the delivery date from the factory and no more than one month after the installation. If the product is registered at a later stage, the warranty period will be affected.

The product registration is done as part of the start-up guide in the Quantum app.

## Environmental information

### Recycling



At the end of the electrical products useful life, it must not be disposed of with household waste.

Recycle at waste facility. Check with your local authority or retailer for local recycling regulations.

Air filters are consumables.

### Packaging content

The product packaging contains the following materials.

<b>MATERIAL</b>	<b>WEIGHT</b>
Paper	5000 g
Plastic	220 g
Wood (pallet)	5 kg

## 2 BEFORE INSTALLING

### Transport

The product must be kept dry during storage and transport. At arrival, ensure that the product was not damaged during transport.

### Installation area

Install the product using the supplied wall bracket.

- The area is not noise sensitive. The product is preferably placed against an outer wall.
- If the product is placed next to a noise sensitive area, for example a bedroom, ensure that the adjacent wall is soundproofed.
- It is recommended that pipes connected to the QS be installed away from interior walls adjacent to a noise-sensitive room.

### Setup dimensions

#### CAUTION

A minimum of 800 mm free space must be available in front of the product.

#### NOTE

For ease of ventilation installation, it is recommended that 300 mm of free space is available above the product.

A minimum of 10 mm clear space should be maintained on both left and right-hand side of the product.

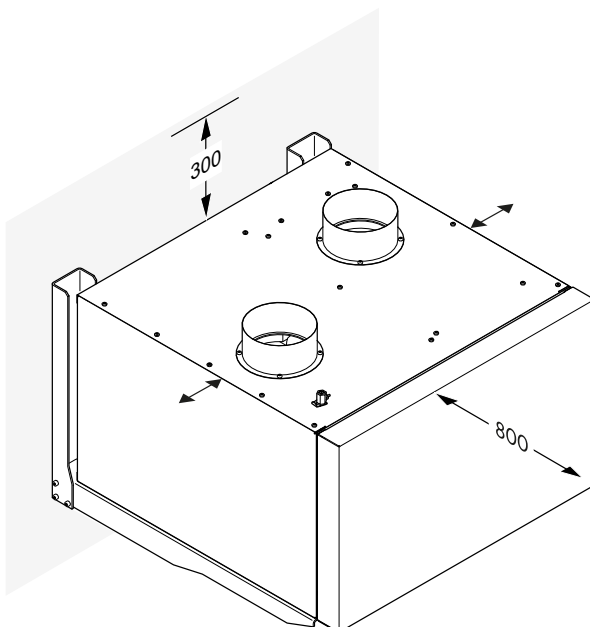

## Additional components

### Supplied components

The supplied components package contains the following items:

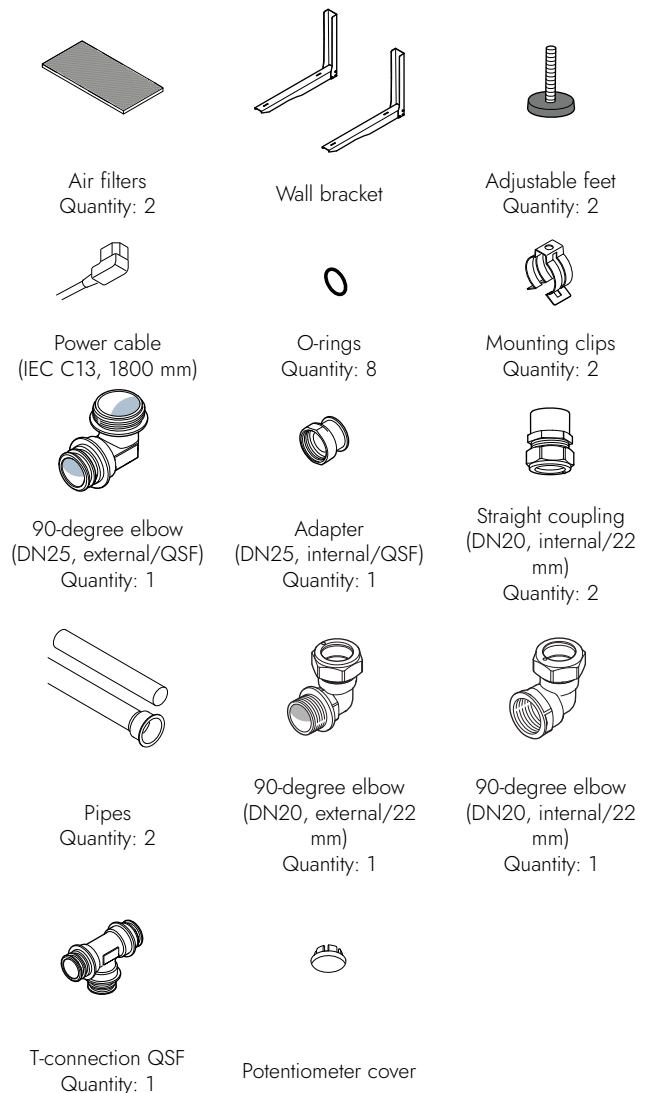

## Front cover removal

The front cover of the product is mounted with clips that are on the frame of the product. The cover rests on brackets that are on the top of the frame.

1. Carefully pull the bottom of the cover from the product.
2. Lift the cover upwards.

3. Remove the cover from the product.

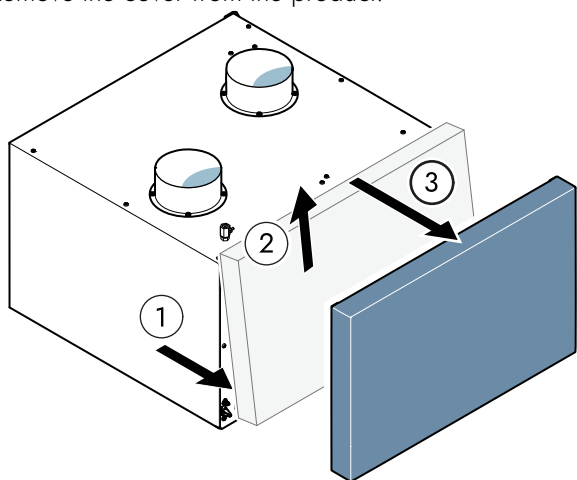

# 3 COMPONENTS

## Overview

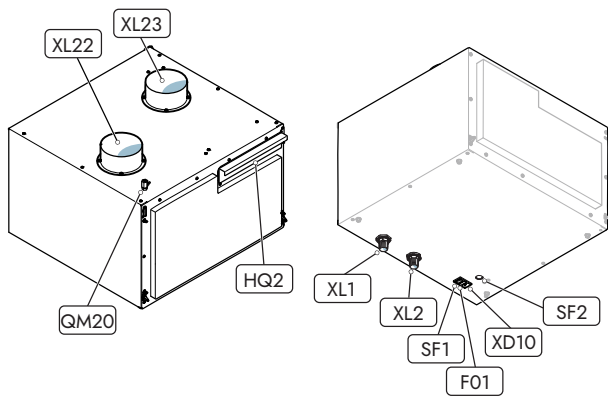

ID <sup>1</sup>	COMPONENT
F01	Fuse (2 A, slow)
HQ2	Supply air filter
QM20	Bleed valve, distribution system
SF1	Switch, power supply
SF2	Potentiometer, air flow
XD10	Socket, power supply
XL1	Distribution system, supply line
XL2	Distribution system, return line
XL22	Connection, supply air
XL23	Connection, outside air

<sup>1</sup> Component designations in accordance with IEC 81346.

# 4 WALL MOUNT INSTALLATION

## Positioning

**NOTE**

Using the supplied pipe, QS can be positioned a maximum of 49 mm to the right or a maximum of 412 mm to the left of the heat pump.

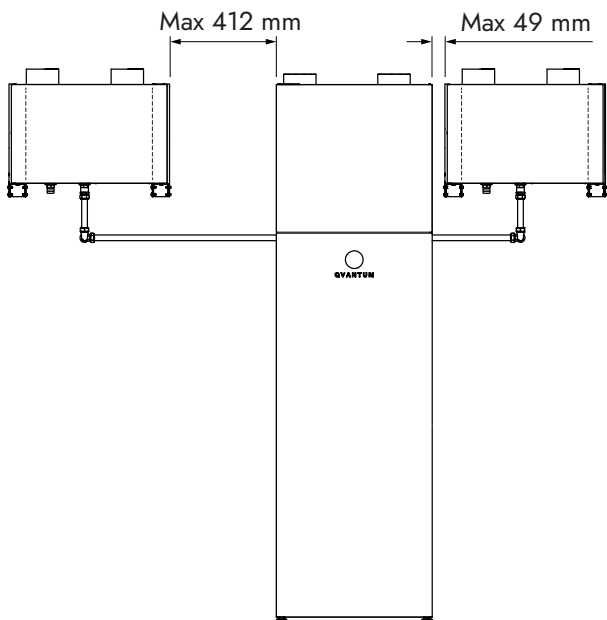

## Installation

**CAUTION**

Ensure that the wall can handle the product's weight (37 kg).

**NOTE**

Fan noise can be transmitted to the wall brackets.

**NOTE**

Screws and plugs for fastening the wall mount to the wall is not supplied.

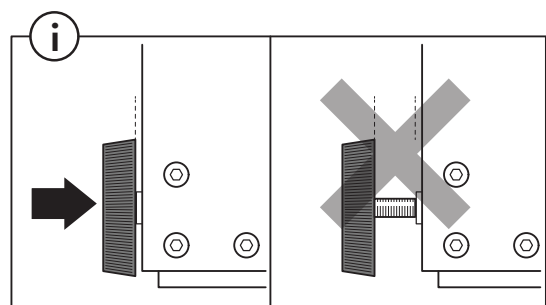
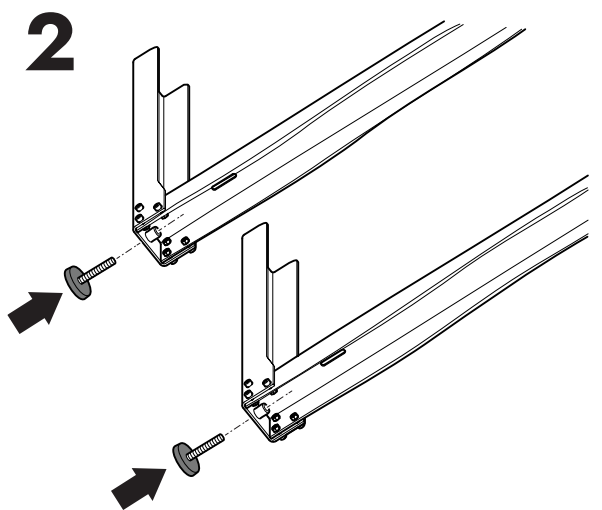
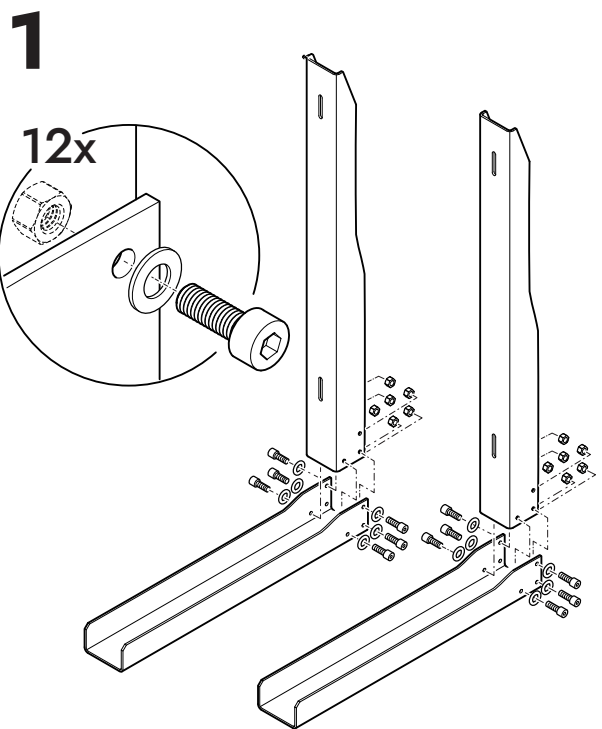

**3**

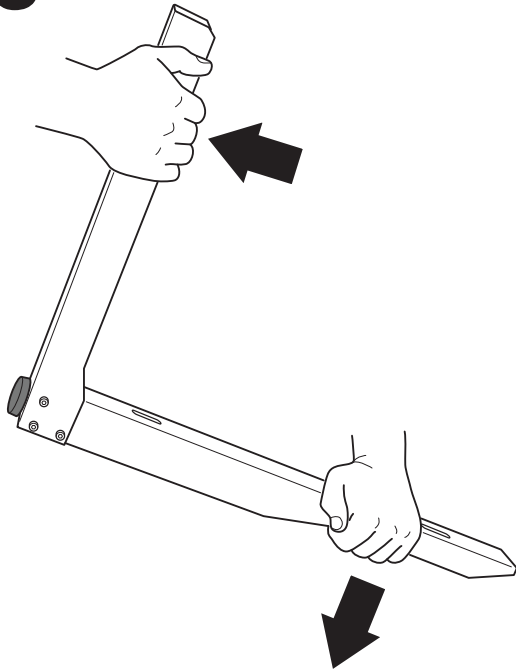

**5**

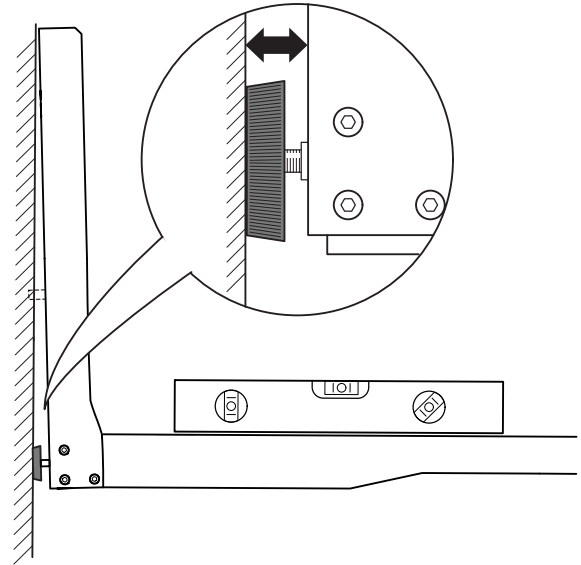

**4**

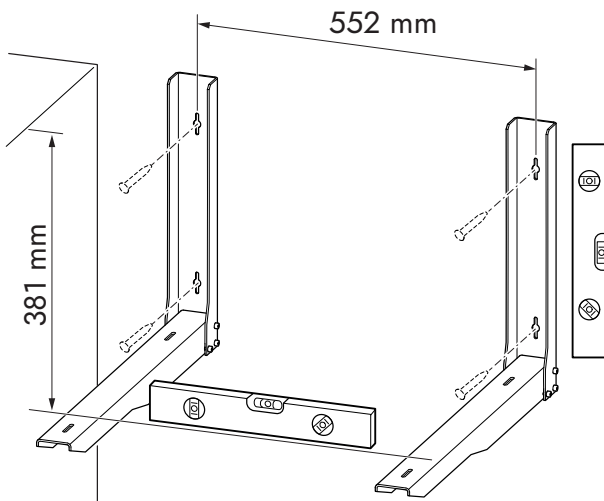
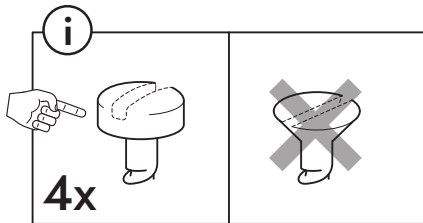

**6**

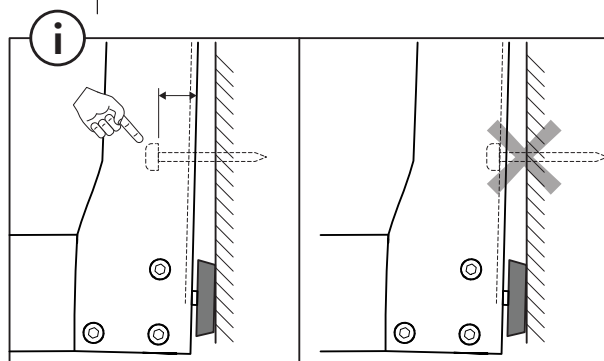
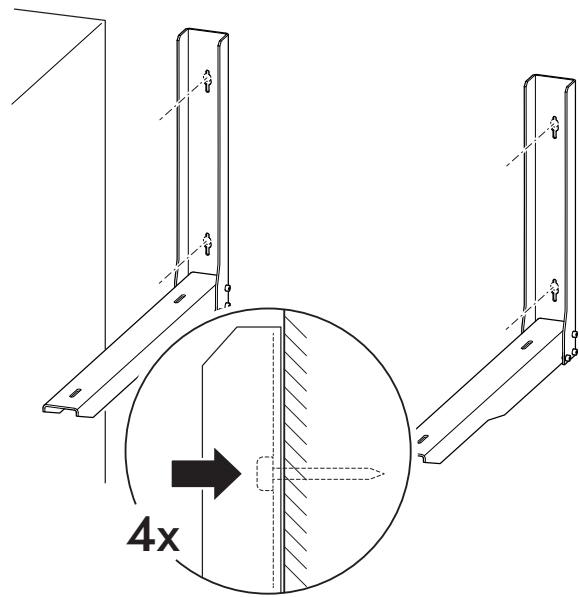

7

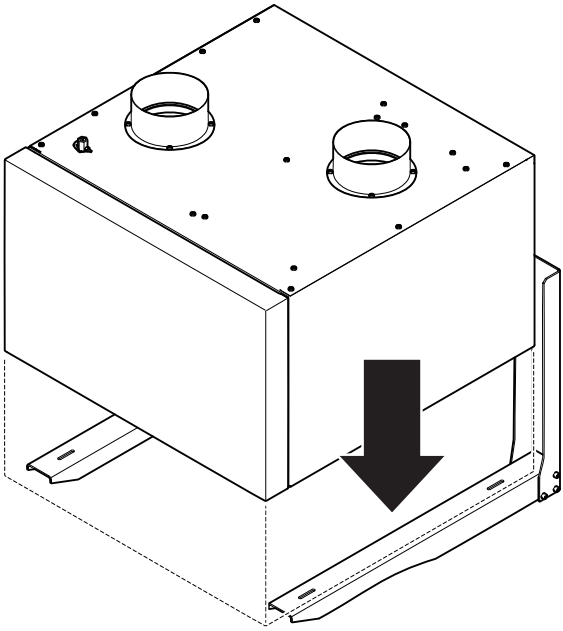

8

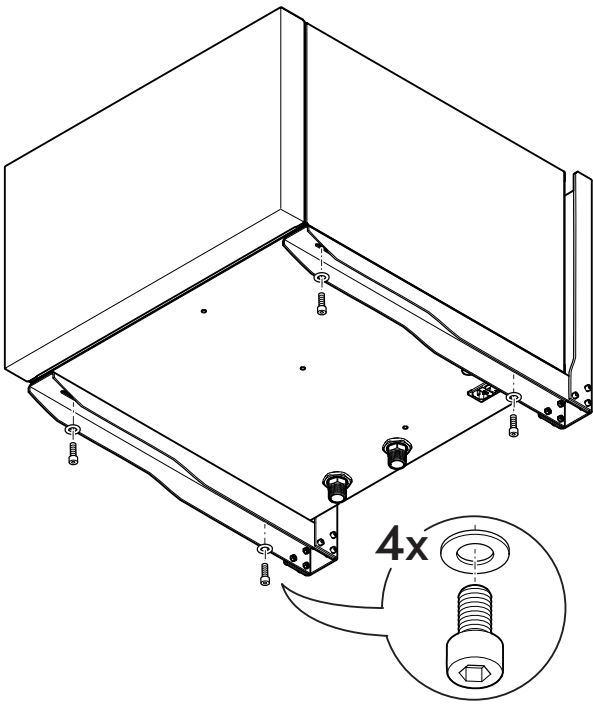

# 5 PIPE INSTALLATION

## Pipe installation, general

**NOTE**

The pipe installations must be performed in accordance with applicable regulations.

Quantum QS is installed with a Quantum exhaust air heat pump.

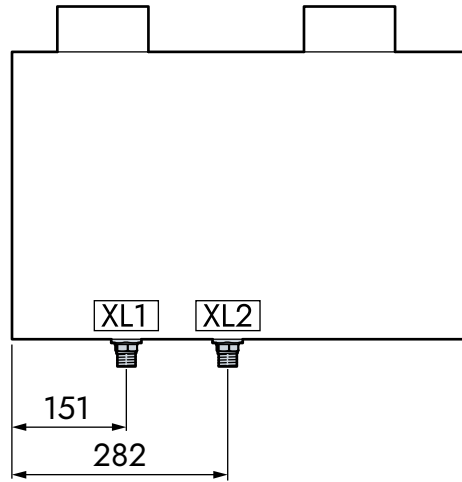
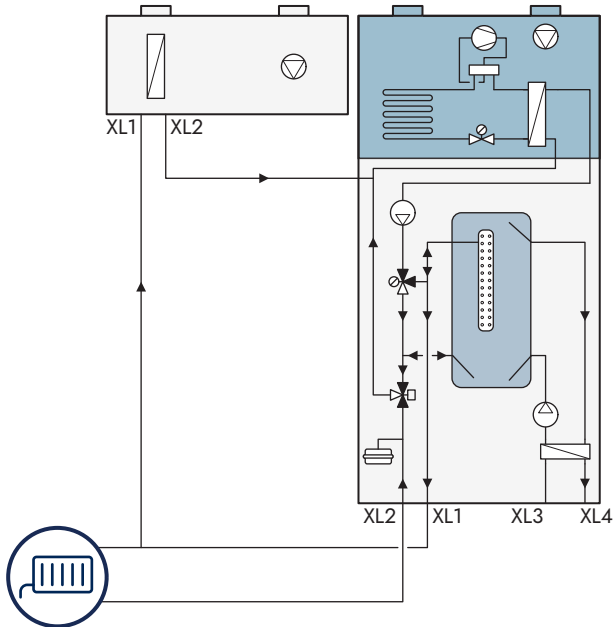

CONNECTION	DIMENSION
XL1, distribution system supply	DN20, external thread
XL2, distribution system return	DN20, external thread

### Installation

**NOTE**

All threaded connections must be sealed. Sealing material is not included with the product.

### Heat pump rebuild

To install QS, the exhaust air heat pump must be modified. The rebuilding affects the rear right-hand side of the exhaust air heat pump, viewed from the back.

The heat pump rebuild procedure is different if the heat pump has a T-connection or a 90-degree elbow that is already installed.

If the exhaust air heat pump is installed with a T-connection:

## Pipe connections

### Measurements and dimensions

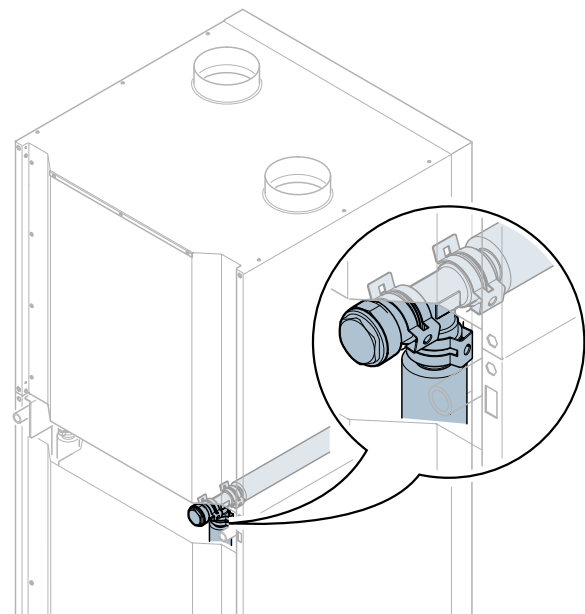
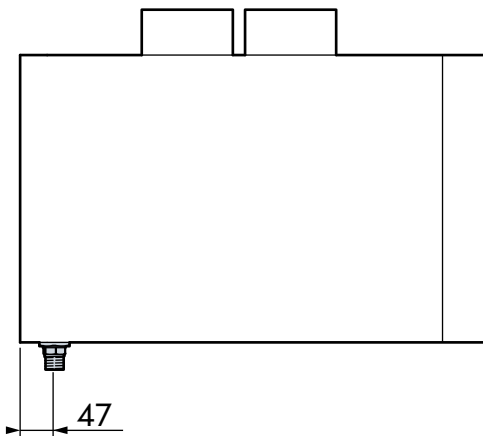

- Remove the plug from the T-connection.

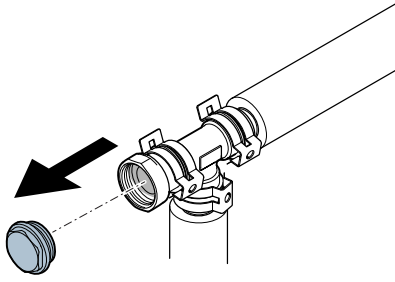

**NOTE**

Start the installation procedure at step 5.

If the exhaust air heat pump is installed with a 90-degree elbow:

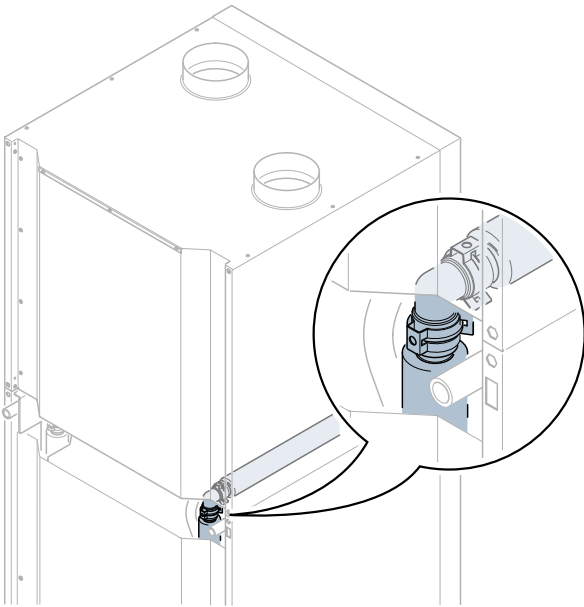

1. Remove the mounting clips that hold the 90-degree elbow.

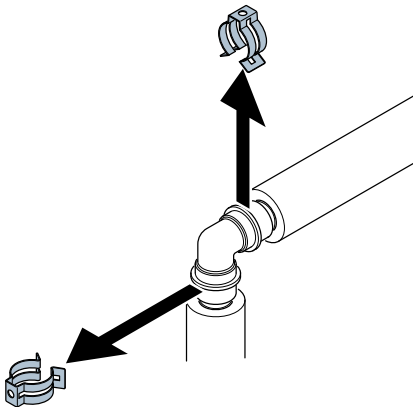

2. Remove the 90-degree elbow.

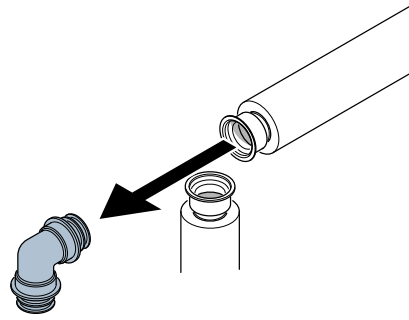

3. Attach the supplied O-rings and T-connection to the pipe connections.

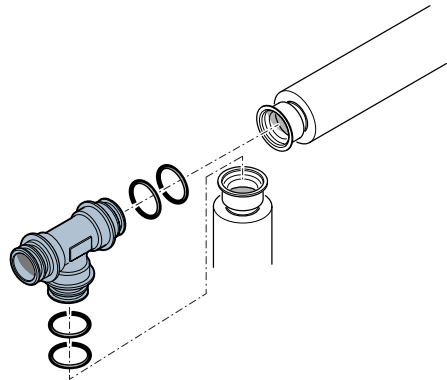

4. Attach the supplied O-rings and adapter (DN25, internal/QSF) to the T-connection.

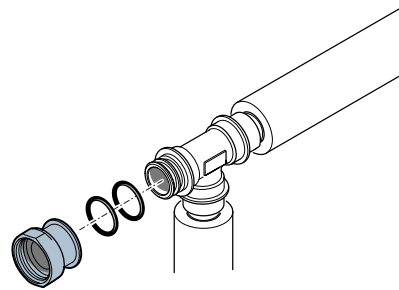

5. Attach the supplied 90-degree elbow (DN25, external/QSF).

a) Rotate the elbow so the outlet is directed towards the supply air module.

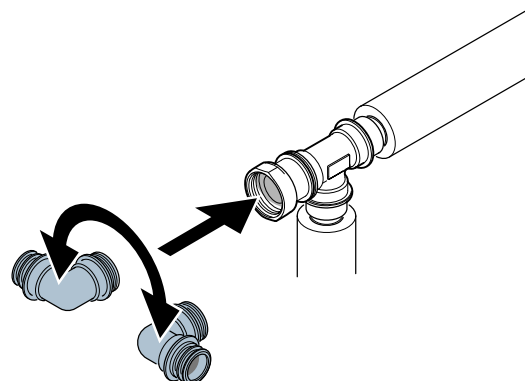

6. Insert the supplied O-rings into the connection.
  - a) Cut the supplied pipe to an appropriate length and mount it on the 90-degree elbow.

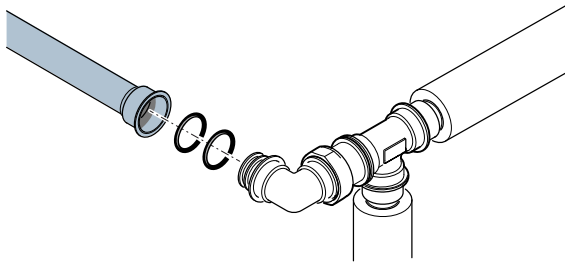

7. Attach mounting clips to all pipe junctions.

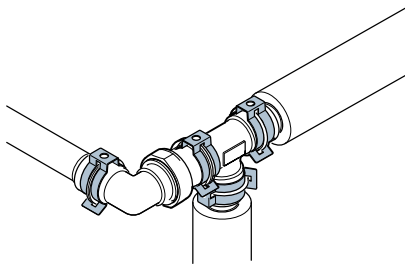

### Distribution system

1. Attach the supplied straight couplings to the pipe connections XL1 and XL2.
2. Attach the supplied short pipe to the straight coupling on the return connection (XL2).
3. Attach the supplied 90-degree elbow (DN20, external/22 mm) to the short pipe.
4. Attach the supplied 90-degree elbow (DN20, internal/22 mm) and connect it to the return line.

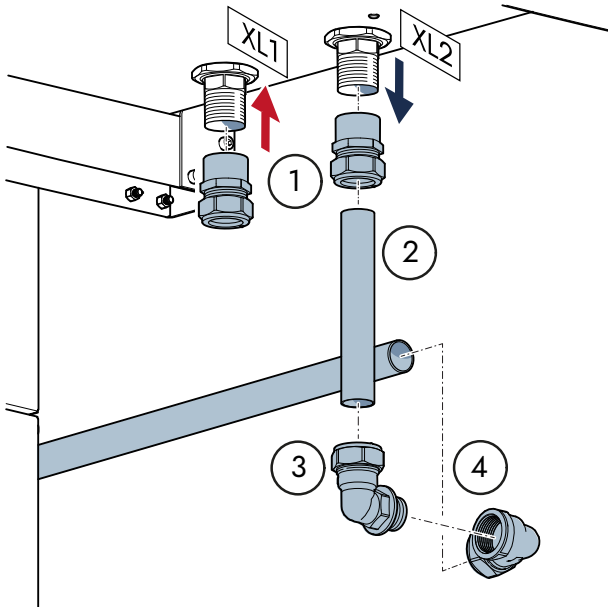

5. Connect the supply line to the supply connection (XL1).

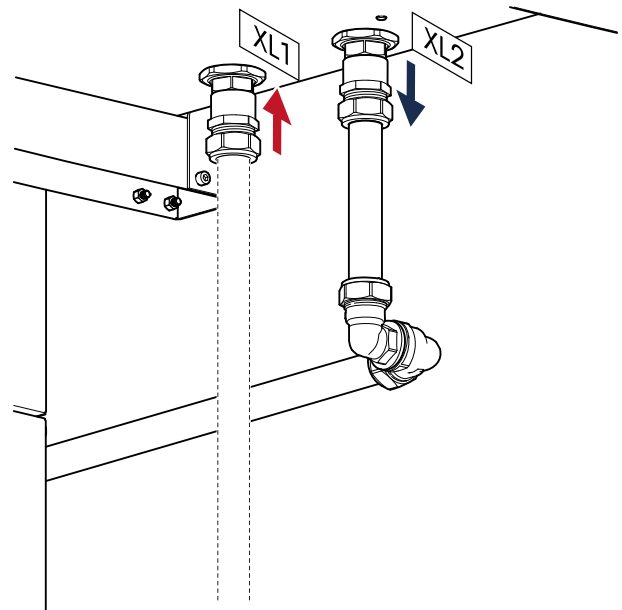

### NOTE

The connecting pipe is not supplied by Qvantum.

## Capacity declaration

### Flow rate to differential pressure

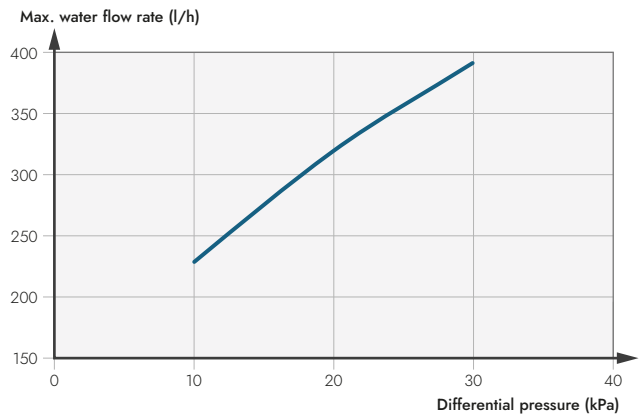

### Heat capacity and required water flow rate 35°C supply line temperature

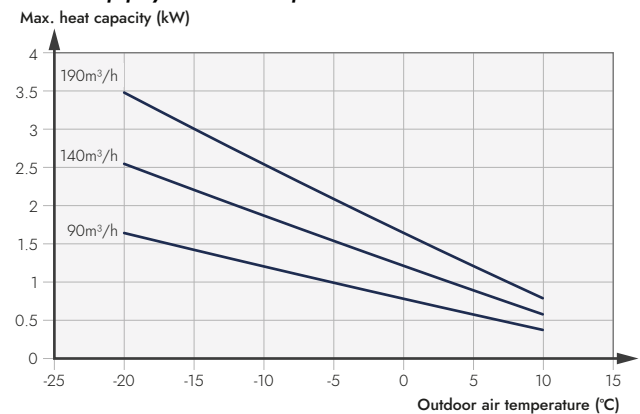

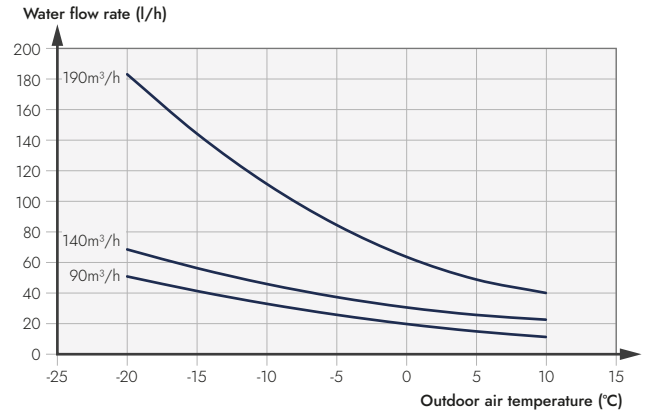
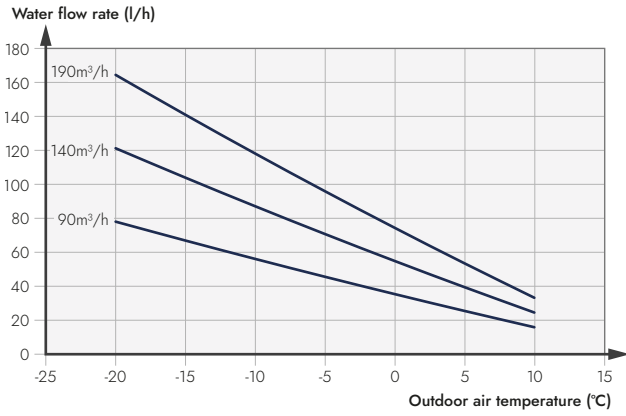

### 45°C supply line temperature

Max. heat capacity (kW)

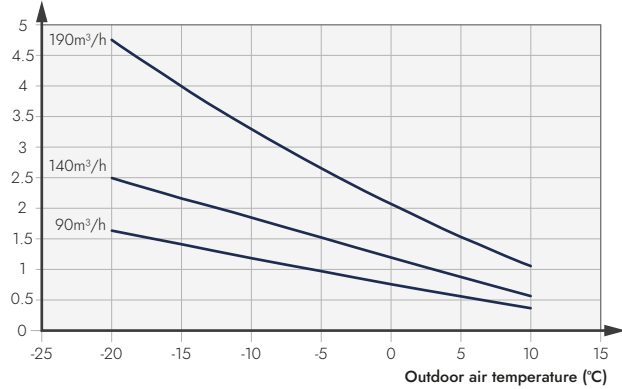

Water flow rate (l/h)

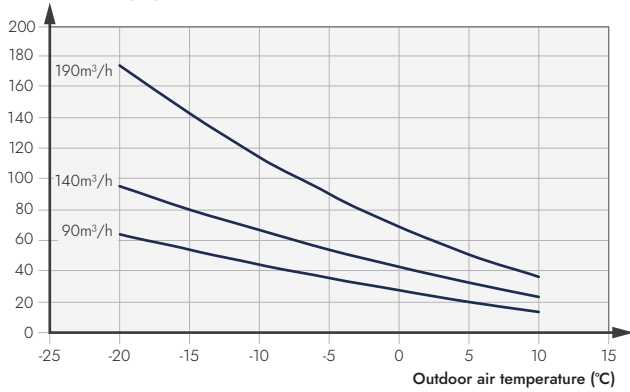

### 55°C supply line temperature

Max. heat capacity (kW)

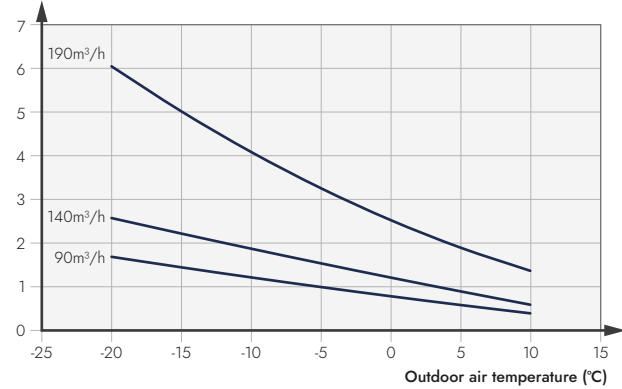

# 6 VENTILATION INSTALLATION

## Ventilation installation, general

QS is connected to the ventilation ducts through the connections for supply air (XL22) and outside air (XL23).

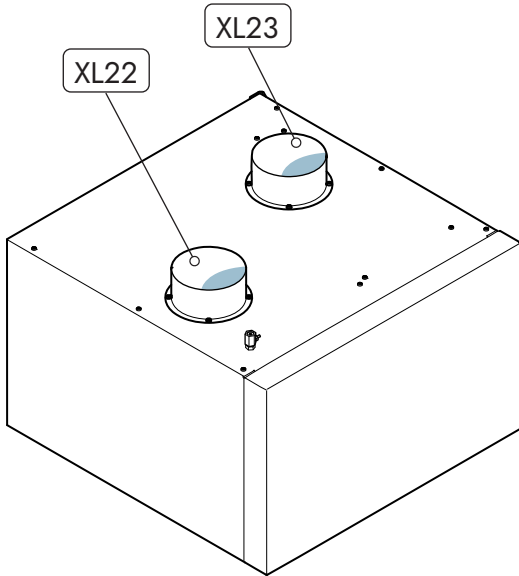

### NOTE

The ventilation installation must be performed in accordance with applicable regulations.

- Connect the ventilation with flexible hoses and ensure that they are easily replaceable.
- Ensure that there is enough room to properly maintain the duct.
- Ensure that the ventilation capacity is not decreased due to creasing or sharp bends in the duct work.
- Ensure that the duct system has a minimum of class ATC 4 air tightness.
- To avoid unwanted transportation of fan noise, it is recommended that silencers are installed at appropriate locations throughout the duct work.
- Ensure that the heat pump runs when using units that affect the ventilation, for example a kitchen fan.

### TIP

Extra insulation on the ventilation ducts in the installation room can further reduce the noise level.

## Ventilation connections

1. Install the ventilation duct hoses (2), pull them down towards the ventilation connection (1) until they reach the case of the unit.

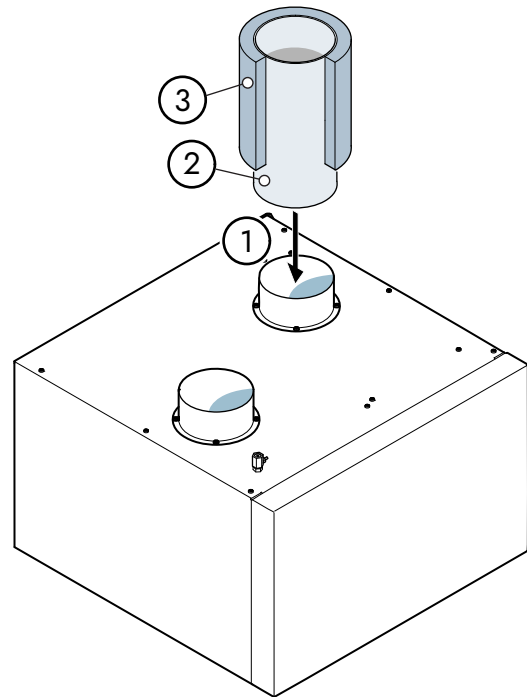

2. Insulate the ventilation duct work with recommended insulation (3) types.  
Fully seal the condensation insulation at all joints and gaps.

## Outside air

### CAUTION

When installing the QS in a cold region, the outside air duct must be equipped with external cold-draft protection.

### CAUTION

Inadequate condensation insulation increases the risk of condensation precipitation, which can cause structural damage.

- Insulate the outside air duct along its entire length with diffusion-proof insulation with a thickness equivalent to at least 18 mm cellular rubber foam.
- Route the outside air to the outside air connection through a grate located on the exterior of the house.

### CAUTION

Ensure that the grate is installed so that rain or snow cannot damage the facade or get inside the air duct.

### CAUTION

Do not use a chimney duct for outside air.

## Measurements and dimensions

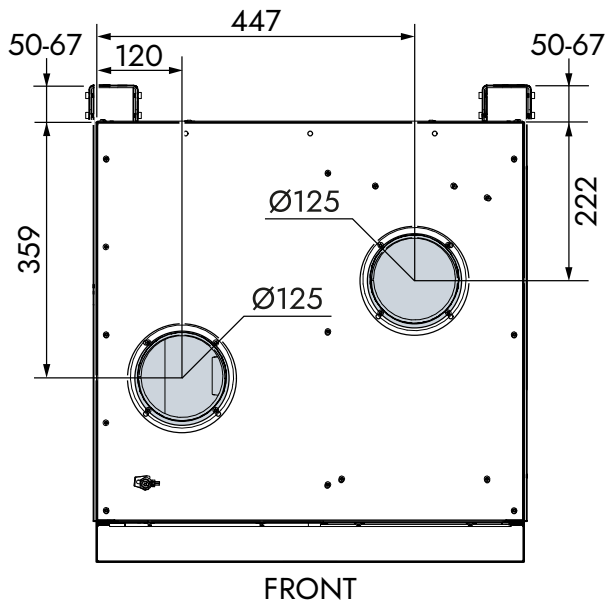

## Ventilation flow and adjustments

### NOTE

If the ventilation is not adjusted correctly, it may reduce the efficiency of the system. Insufficient air exchange can cause moisture-related damage to the house.

The ventilation flow must be set up in accordance with local regulations.

### CAUTION

To prevent overpressure in the building, make sure that the supply air flow rate is lower or equal to the exhaust airflow rate.

## Ventilation capacity

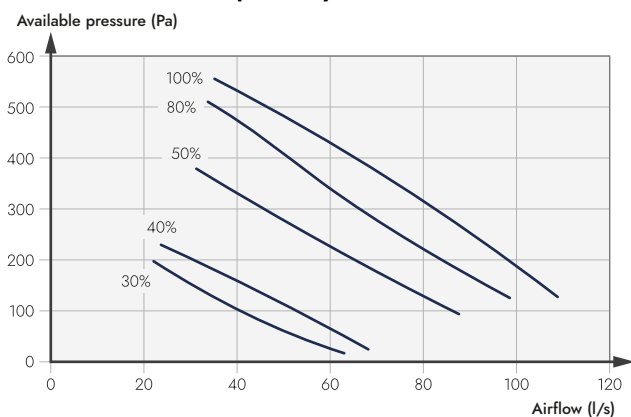

# 7 ELECTRICAL INSTALLATION

## Electrical installation, general

### **WARNING**

All electrical connections must be performed by a qualified electrician and in accordance with applicable regulations.

The product is supplied with a power cable.

## Power supply

1. Connect the power cable to power supply socket (XD10).

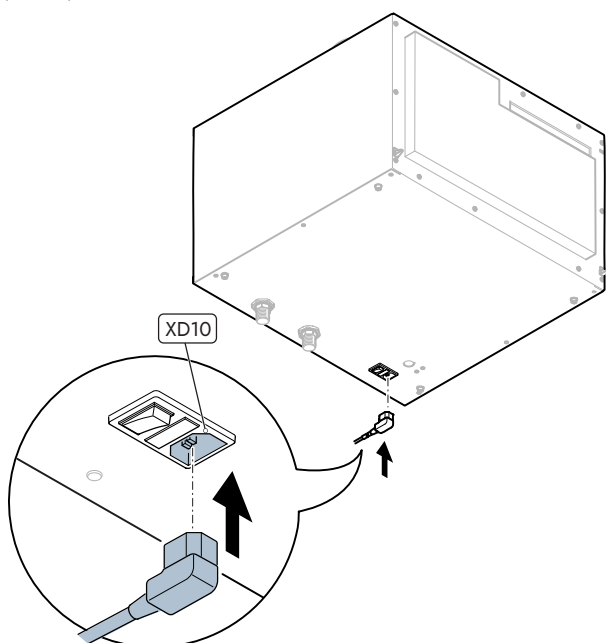

2. Connect the power cable to wall socket.

# 8 COMMISSIONING

## Quantum app

To properly set up the unit, install the Quantum app and follow the in-app instructions for the main unit.

The app contains an installation checklist where the QS must be activated.

## Preparations

### NOTE

Do not power on the QS until the product and distribution system are filled and purged.

## Filling

### Distribution system

- Turn off the power to the heat pump and the QS.
- Fill the distribution system.

## Venting

- Purge the unit by opening the bleed valve (QM20).
- Refill and purge the distribution system until all air is removed and adequate system pressure is reached.

### NOTE

Make sure that the system is properly purged before the heating season, as air trapped in the QS can cause the heat exchanger to freeze in cold weather.

## First start-up

### CAUTION

Before the first start-up, ensure that there is no frozen water in the system.

### NOTE

Before the first start-up, ensure that there is water in the distribution system.

1. Turn on the heat pump.
2. Turn on the QS.
  - a) Press the power supply switch (SF1) to turn on the QS.

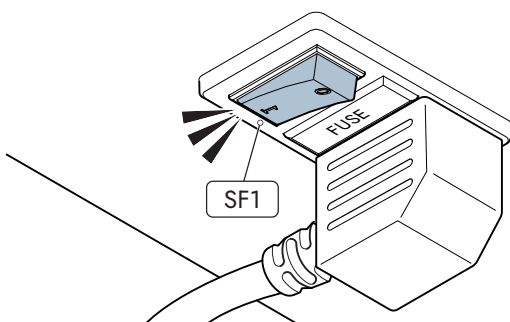

3. Run the system to ensure it is operating correctly.

## Setting up the ventilation

The ventilation flow must be adjusted according to the planned specifications of the house.

### NOTE

A professional ventilation adjustment must be conducted.

## Potentiometer adjustment

Manually adjust the potentiometer (SF2) to control the supply air flow to meet specific ventilation requirements.

1. Turn the potentiometer to adjust the airflow.
  - a) Turn the potentiometer clockwise to increase the airflow.
  - b) Turn the potentiometer counter-clockwise to decrease the airflow.

### NOTE

Start with small adjustments to avoid drastic changes in the system performances.

2. Insert the supplied potentiometer cover.

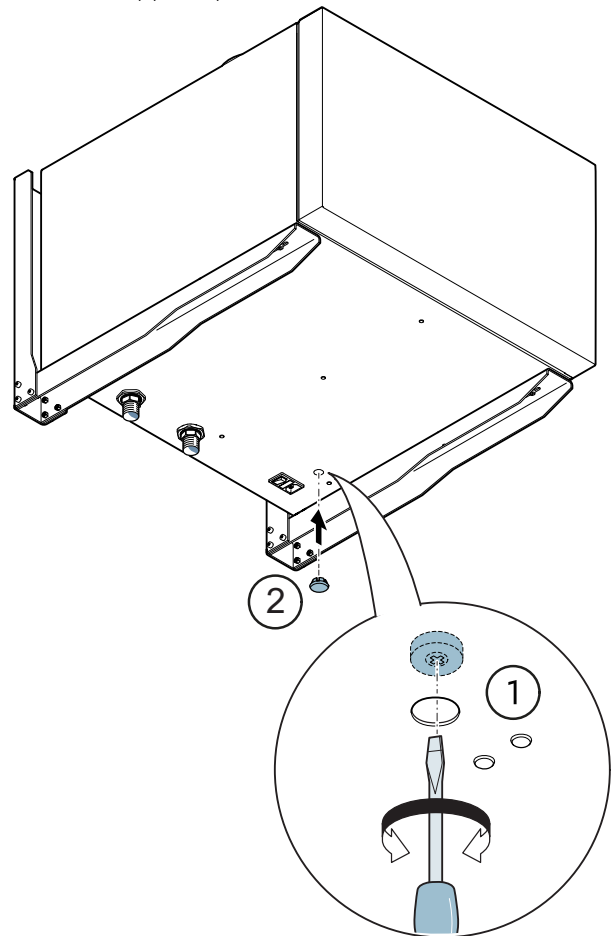

# 9 SERVICE

## General

### CAUTION

Maintenance and servicing must be performed by persons with sufficient knowledge about the task.

## Maintenance

### NOTE

The end user must be informed about necessary maintenance actions.

## Filter change

### CAUTION

The unit must be turned off before the filter change.

The supply air filter must be replaced on a regular basis. It is recommended to replace the filter four times a year or as necessary.

The filter cartridge is accessed by removing the front cover of the unit.

Order new filters by contacting your local Quantum sales department.

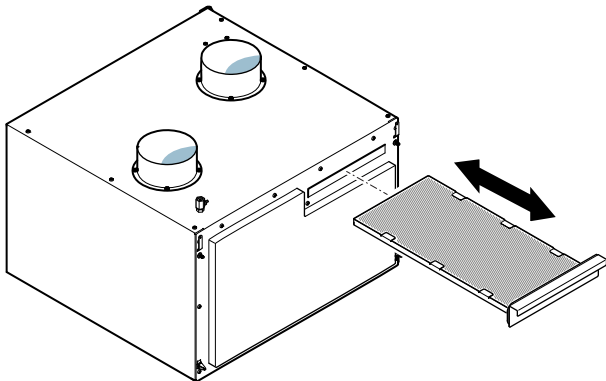

1. Remove the used filter.

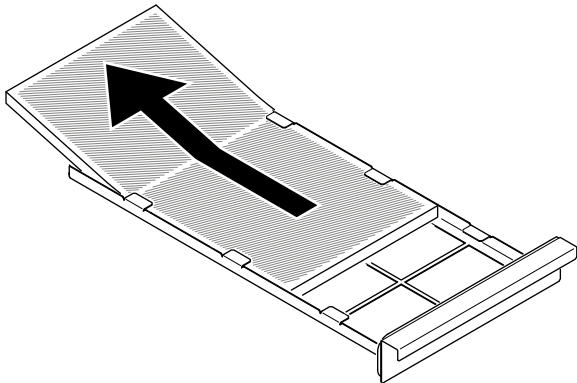

2. Clean the filter cartridge.

3. Insert the new filter by sliding it into position below the filter cartridge tabs.

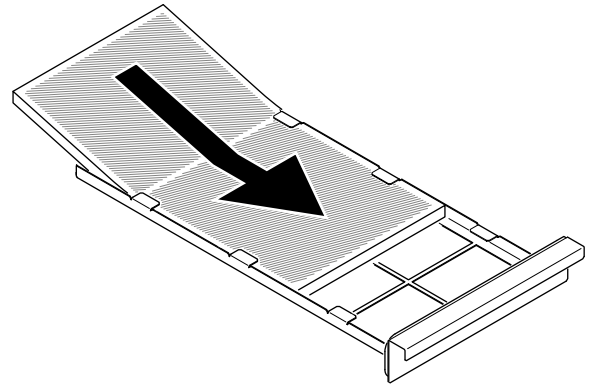

4. Reinstall the filter cartridge.

# 10 TROUBLESHOOTING

## Before troubleshooting

If the system does not inform about an active fault, check the following components before troubleshooting:

- Power supply.
- Group and main fuses of the property.
- Residual current device (RCD).
- Safety temperature limiter (*FQ10*) in the heat pump.

## Insufficient ventilation

**The ventilation is insufficient or missing.**

### Blocked filter

- Clean or replace the filter.

### Ventilation set-up not done

- Perform ventilation adjustments.

### Reduced air flow at supply air diffuser

- Clean supply air diffuser.
- Check adjustments of supply air diffuser.

## Abnormal ventilation noise

### Blocked filter

- Clean or replace the filters.

### Ventilation set-up not done

- Perform ventilation adjustments.

## Low supply air temperature

**Air in the distribution system.**

- Purge the QS with the bleed valve (*QM20*).

**Incorrect potentiometer setting.**

- Adjust the potentiometer to increase fan speed and airflow.

# 11 TECHNICAL SPECIFICATIONS

## Dimensions

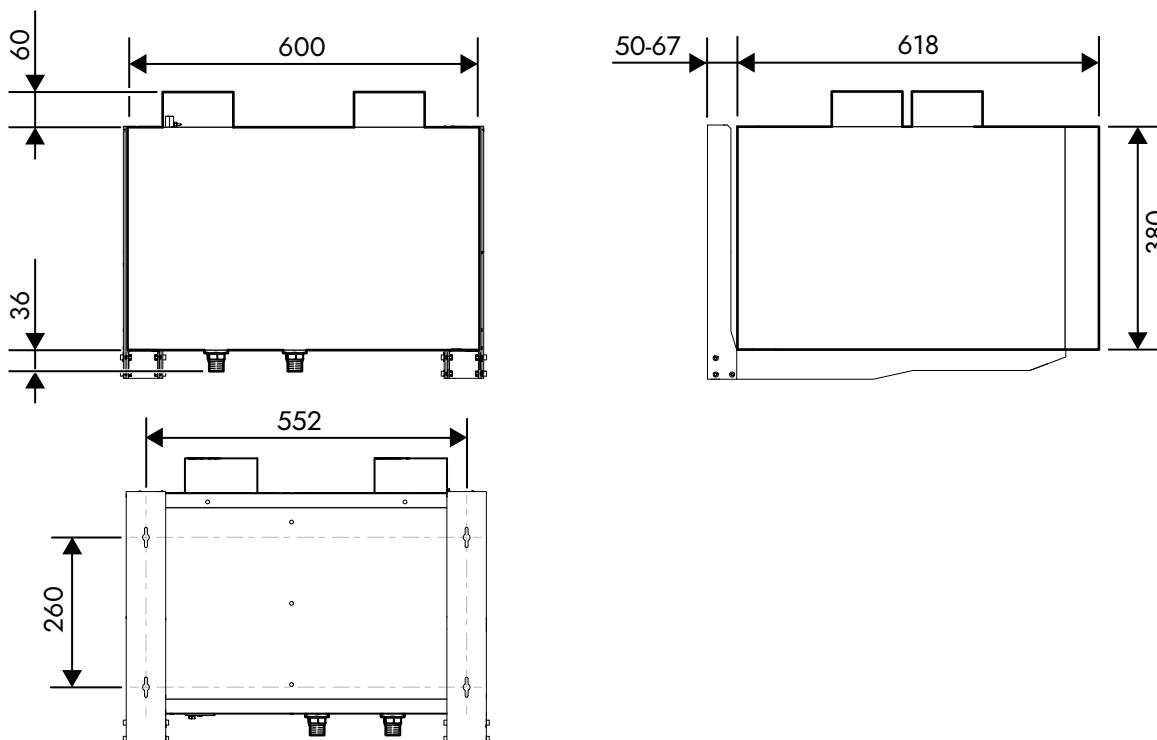

## Technical data

### QUANTUM QS

#### Heating medium circuit

Max pressure	MPa/bar	0.25/2.5
--------------	---------	----------

#### Ventilation

Max. recommended air flow	l/s	70
Filter class		EPM1 70%

#### Electrical data

Rated voltage	V	230V ~ 50Hz
Driving power fan	W	18-90
Enclosure class		IP 21

#### Sound data

Sound power level ( $L_{W(A)}$ ) <sup>EN12102</sup> <sup>1</sup>	dB(A)	36-49
Sound pressure level in installation area ( $L_{P(A)}$ ) <sup>1</sup>	dB(A)	32-45

#### Connection dimensions

Heating medium, external thread		DN20
Ventilation	mm	125

#### Weight and dimensions

Weight <sup>2</sup>	kg	37
W x D x H <sup>3</sup>	mm	600 x 618 x 380

#### Misc.

Part no.		9330042
----------	--	---------

- 1 At airflow rate 190 m<sup>3</sup>/h.
- 2 Weight including the wall mount.
- 3 Height without ventilation connections.

# Index

## B

- Before installing
  - Additional components [5](#)
  - Front cover removal [5](#)
  - Installation area [5](#)
  - Setup dimensions [5](#)
  - Supplied components [5](#)
  - Transport [5](#)

## C

- Commissioning
  - Filling [18](#)
  - First start-up [18](#)
    - Setting up the ventilation [18](#)
  - Preparations [18](#)
  - Venting [18](#)
- Components [7](#)

## E

- Electrical installation [17](#)
  - Power supply [17](#)
- Environmental information [4](#)

## I

- Important information
  - Environmental information [4](#)
  - Product labels [3](#)

## M

- Maintenance
  - Filter change [19](#)

## P

- Pipe installation
  - Pipe connections [11](#)
    - Installation [11](#)
      - Distribution system [13](#)
      - Heat pump rebuild [11](#)
  - Measurements and dimensions [11](#)
  - Pipe installation, general [11](#)

## T

- Technical specifications
  - Dimensions [21](#)
  - Technical data [21](#)
- Transport [5](#)
- Troubleshooting [20](#)
  - Abnormal ventilation noise [20](#)
  - Before troubleshooting [20](#)
  - Insufficient ventilation [20](#)
  - Low supply air temperature [20](#)

## V

- Ventilation installation [15](#)
  - Measurements and dimensions [16](#)
  - Ventilation capacity [16](#)

## Ventilation installation (*continued*)

- Ventilation connections [15](#)
  - Outside air [15](#)
- Ventilation flow and adjustments [16](#)

## W

- Wall mount installation
  - Installation [8](#)
  - Positioning [8](#)



QIH EN 2540-A



1012559

This publication presents information that was valid at the time of publishing.  
Quantum reserves the right to make changes without prior notification.  
Subject to possible printing errors.  
©2025 Quantum Energi AB

# HEAT PUMPS FOR SUSTAINABLE CITIES

## WE CHANGE THE WAY THE CITIES OF EUROPE ARE HEATED

Quantum, founded in Sweden in 1993, develops high-quality heat pumps for individual buildings and innovative heat pump-based solutions for densely populated areas to enable everybody to benefit from emission free heating and cooling. The company has deep knowledge in both heat pump technology and energy systems engineering and works in close collaboration with engineering consultants, installers, project developers and utilities.

**Quantum Energi AB**

Ji-te gatan 7, 265 38 Åstorp – Sweden | [quantum.com](http://quantum.com)



Q V A N T U M