

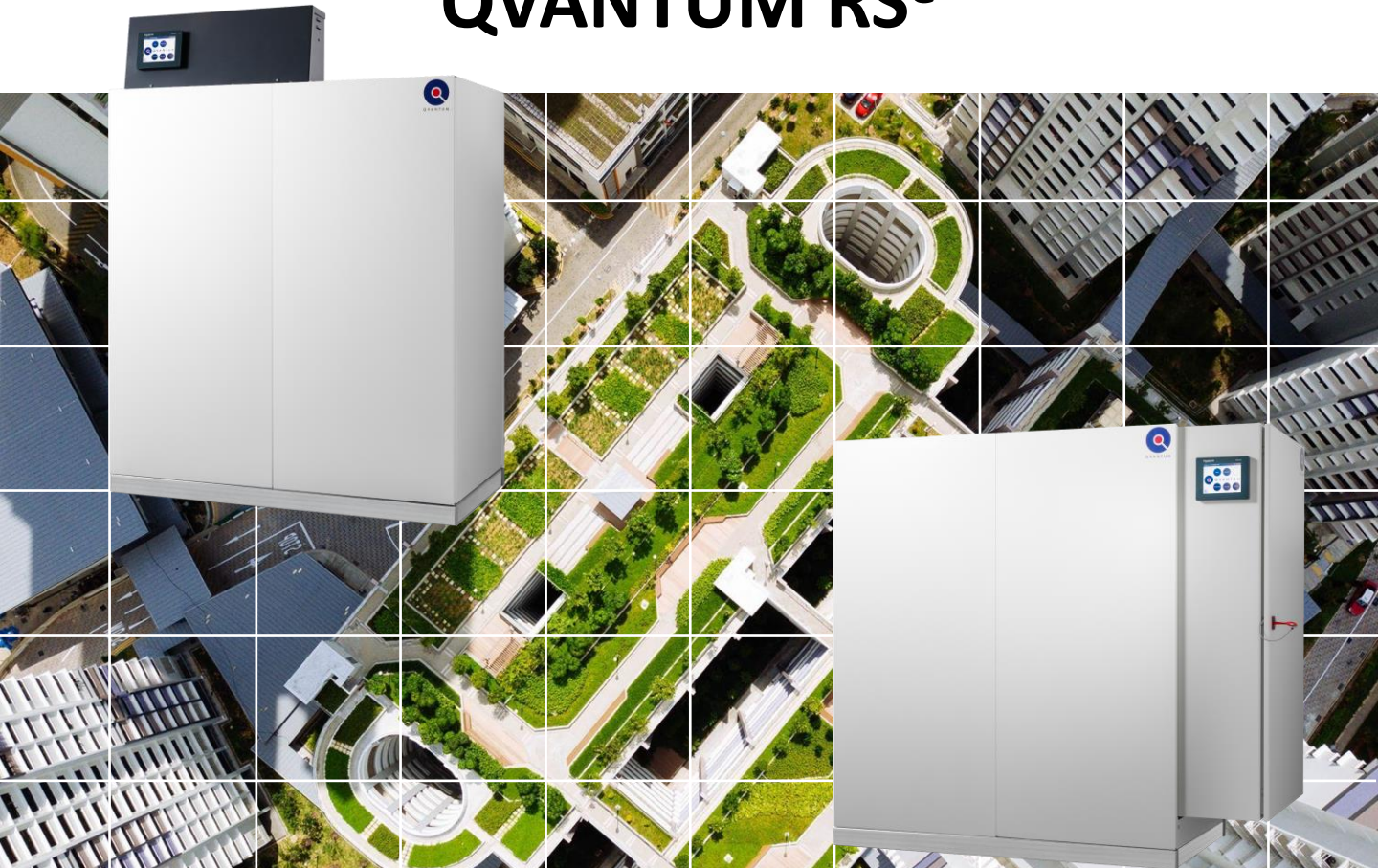

Q V A N T U M

HEAT PUMPS FOR SUSTAINABLE CITIES

QVANTUM RS^e



Heat pumps for liquid-based heat sources

Q32-81RS^e

Liquid/Water
27 – 96 kW



High efficiency
Refrigerant R-513A
Compact design
Flexible installation

Quantum RS^e – Heat pumps with refrigerant R-513A

GENERAL

Quantum RS^e is intended for use in systems where the brine consists of a mixture of water and antifreeze (e.g. surface soil heating systems, geothermal heating systems, sea water systems, exhaust air system).

QUANTUM QLC-SYSTEM

Quantum RS^e is equipped with the Quantum QLC control system as standard. QLC stands for Quantum Logic Controller. The unit is controlled and operated via the principal of liquid condensation or solid/half solid condensation. All control parameters such as outdoor temperature compensated set-point curve for supply, hot water temperature, auxiliary heat, are set via the self-instructing control system. Required protection and safety functions are available in QLC control systems.

The system is managed via a 5,7" panel mounted in the heat pump. All parameters can be set via the panel. The panel displays a dynamic flow diagram with all temperatures and operating modes measured and controlled. The QLC system also logs temperatures and events, facilitating set-up and analysis. The system communicates via Modbus. Modbus TCP is standard. The system also has a web server which allows the QLC system to communicate with a web browser on a PC or smartphone (app may be needed).

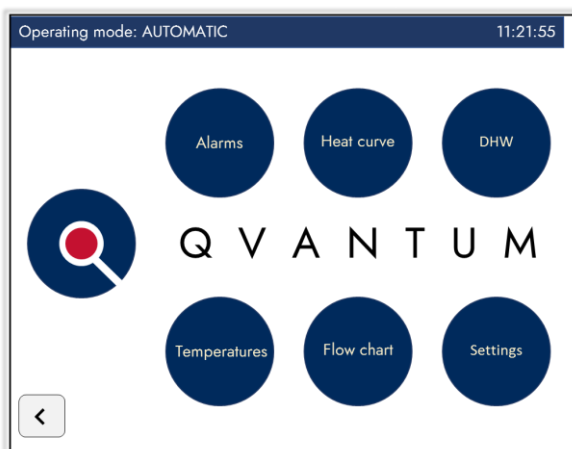

Fig 1. 5,7" panel display.

As an option, the unit can be equipped with an extended display that allows for dynamic flow images and extended network functionality.

The temperature to the heating system is controlled according to the selected outdoor temperature compensated curve. Hot water preparation, if such a function is required, takes place via a switching valve that momentarily raises the temperature in the water heater to the set point as a priority.

In bivalent systems, the control system switches on additional heat when needed and after a time delay. The auxiliary heat can be chosen to "take over" the hot water preparation as a first step and thus release power from the heat pump to the heating system.

The Quantum control system can control up to 8 heat pumps in sequence with automatic operating time equalization between the different heat pumps. The control system is configured at commissioning depending on the selected system solution and the type and number of heat pumps.

The heat pump/control system can be configured for control via an overlaying external control system if required. Set points can be changed via Modbus so that the controller's regulators are set by the master controller. It is also possible to configure the system so that the heat pump is fully controlled by the master system. In this case, the heat pump control system is used only for alarm and protection functions.

E.g., Temperatures readable via Modbus *)

- 1: Heat pump heat carrier - in
- 2: Heat pump heat carrier - out
- 3: Heat pump hot gas temperature
- 4: Heat pump brine - in
- 5: Heat pump brine - out
- 6: Radiator circuit supply
- 7: Outdoor temperature

*) Modbus description for complete information

All relay outputs are also readable. It is thus possible to transmit the operating status of compressors, pumps, fans, etc. controlled by the heat pump.

Set points for hot water temperature and control curve for radiator circuit can be read and adjusted. From the expansion valve control unit, the current evaporating temperature, pressure, overheating, the degree of opening of the expansion valve can be monitored via Modbus.

ELECTRONIC EXPANSION VALVE

Quantum RS^e heat pumps are equipped with electronic expansion valve. The expansion valve have its own electronic control unit with display that shows, evaporation pressure, temperature, overheating, etc. for the circuit. Via Modbus, these variables can be transferred to an overlaying control system.

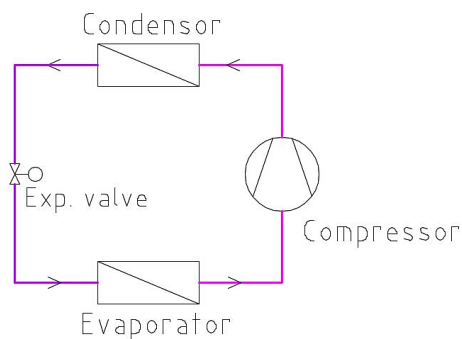

Fig 2. Principal layout showing the refrigerant circuit.

REFRIGERANT

All Quantum RS^e heat pumps have R-513A refrigerant (GWP=573, AR5).

BRINE CIRCUIT

Quantum RS^e heat pumps are configured for brine with antifreeze, e.g. bioethanol.

PIPE CONNECTIONS

Q32-41RS^e has top connections. See drawing Q-RSe-32-41-001.

Q48-81RS^e has back connections. See drawings Q-RSe-48-001 and Q-RSe-65-81-001.

CONSTRUCTION

The unit is built on a robust stand of galvanized square tubes and covered with an effective sound-absorbing casing, consisting of powder-coated plates with sound-absorbing material on the inside. The top plate is made of patterned aluminum. The top and bottom are also covered with sound-absorbing material. The stand rests on adjustable rubber feet.

ACCESS

The unit is constructed so that all components inside the heat pump are easily available by removing the cover plates, both for maintenance and replacement.

OPTIONS

The following options are available:

- Connecting QLC to network.
- Electrical cabinet mounted on the left side of the unit, seen from the front (applies to Q65-81RS^e).
- Hot gas heat exchanger
- Reversible function.

EQUIPMENT

Compressor

All units are equipped with fully hermetic scroll compressors, 3-phase 400V. Q32RS^e till Q48RS^e are equipped with 2 compressors. Q65RS^e till Q81RS^e are equipped with 3 compressors.

Cooling circuit

All units are equipped with 1 cooling circuit.

Heat exchanger

- The evaporator is a stainless steel, brazed plate heat exchanger, insulated with Armaflex insulation.
- The condenser is a stainless steel, brazed plate heat exchanger.
- The hot gas heat exchanger (option) is a stainless steel, brazed plate heat exchanger.

Refrigerant circuit

- Drying filter
- Sight glass with moisture indicator
- Electronic expansion valve, pressure transmitter, control equipment with display (Modbus) for the main circuit
- High- and low-pressure switch, manual reset
- Service valves for pressure measurement
- Rotalock valves
- Pressure protection equipment, high and low pressure

TESTING

The units are test run and calibrated under design conditions using ClimaCheck.

TECHNICAL DATA

See separate document "Quantum RS^e – Technical data" for more information.



Solution and Heat Pump Experts

Quantum was founded 1993 with a vision to develop innovative high quality heat pumps. Today Quantum continues on this path developing the solutions needed for decarbonization of our cities.

Quantum is also a company with leading experts in the design of the next generation (5th) district heating and cooling solutions for dense urban areas.

By combining these competence areas, Quantum can provide solutions that will make it easier for Engineering consultants, Installers, Project developers and Utilities, to decarbonize the heating and cooling of our cities.

